



TABLE OF CONTENTS

SECTION I - INTRODUCTION	1
A. OVERVIEW.....	1
B. MACHINE SPECIFICATIONS	1
C. CARE AND SAFETY PROCEDURES.....	2
D. THEORY OF CONDITIONING OPERATION	3
SECTION II - MACHINE DESCRIPTION	4
A. REAR; CENTER; FRONT; RIGHT; & LEFT SIDE.....	4
B. KEYPAD.....	5
C. CONDITIONING (REAR) END COMPONENTS.....	6
D. CENTER COMPARTMENT COMPONENTS	8
E. CLEANING (FRONT) END COMPONENTS	10
F. BOTTOM SIDE COMPONENTS.....	16
G. RIGHT SIDE COMPONENTS	17
H. LEFT SIDE COMPONENTS	18
SECTION III - PRE-INSTALLATION	1
SECTION IV - OPERATING INSTRUCTIONS	1
A. FILLING THE CONDITIONER TANK	1
B. FILLING OF CLEANER SUPPLY TANK.....	2
C. TURNING THE UNIT ON.....	3
D. KEYPAD DISPLAY	4
E. OPERATORS MENU SELECTIONS	5
1. <i>Run Mode</i>	5
2. <i>Manual Reverse Menu</i>	6
3. <i>Program Override Menu</i>	7
4. <i>System Upgrade Menu</i>	7
5. <i>Change Program Menu</i>	10
6. <i>System Control Cleaning Menus</i>	22
7. <i>System Control Duster Menus</i>	25
8. <i>Auto Program</i>	27
9. <i>Test Output</i>	29
10. <i>Copyright</i>	30
11. <i>Set Time/Day Menu</i>	31
SECTION V - ADJUSTMENTS	1
A. CLEANING CLOTH REPLACEMENT & ADJUSTMENT	1
B. FILLING OF CLEANER SUPPLY TANK.....	3
C. EMPTYING OF RECOVERY TANK	3
D. ADJUSTMENT OF SPRAY JETS.....	4
E. GUIDE ROLLER ADJUSTMENTS.....	5
F. SQUEEGEE ASSEMBLY ADJUSTMENT.....	6
G. BUFFER BRUSH ADJUSTMENT.....	8
H. TRANSFER ROLLER ADJUSTMENT.....	9
I. END CLEANING DISTANCE TRAVEL ADJUSTMENT	10
J. DRIVE MOTOR SPEED ADJUSTMENTS	11

CROSSFIRE Operators Manual

SECTION VI - MAINTENANCE	1
A. POWER CORD	1
B. SQUEEGEE	2
C. LANE-TO-LANE CASTERS	2
D. DRIVE WHEELS	2
E. VACUUM MOTOR.....	2
F. INSIDE MACHINE	2
G. RECOVERY TANK REMOVAL	2
H. FILTERS.....	3
I. WICKING PADS	3
J. BUFFING BRUSH	4
SECTION VII - INPUTS AND OUTPUTS	1
A. INPUTS	1
B. OUTPUTS	2
C. DESCRIPTION OF INPUTS	3
SECTION VIII - PROGRAM DESCRIPTIONS	1
A. SAMPLE PATTERN SETTINGS	3
SECTION IX - APPENDIX	1
A. RECOMMENDED MAINTENANCE INSPECTIONS	1
RECOMMENDED PART REPLACEMENT SCHEDULE	6
B. INSTRUCTIONS TO CLEAN WATER SPRAY PUMP	7
C. TROUBLESHOOTING INPUTS	9
D. MACHINE ERROR MESSAGES	10
E. TECHNICAL SUPPORT INSTRUCTIONS.....	16
SECTION X - MECHANICAL DRAWINGS	1
A. ATTACHING PARTS.....	1
B. PARTS LIST	1

SECTION I - Introduction

A. Overview

This Lane Cleaning and Conditioning Machine represents advanced wick pad technology for automated lane care. Clean and consistent bowling conditions are accomplished through the use of an on-board keypad linked to a programmable computer.

A simple conditioner transfer system, vacuum cleaning and squeegee system, and duster system allow the machine to maintain clean and consistent bowling conditions.

IT IS VERY IMPORTANT THAT THE OPERATOR THOROUGHLY READ AND UNDERSTAND THIS OPERATING MANUAL BEFORE USING THE MACHINE. WHEN ALL ELSE FAILS...READ THE MANUAL OR WATCH INTRO VIDEO.

Should you have any questions regarding any procedures pertaining to the proper operation of this machine, please contact Kegel at (863)734-0200 or by e-mail at LMC@kegel.net.

B. Machine Specifications

Models:

17-5200 Crossfire (115V/60Hz)
17-5250 Crossfire (230V/50Hz)

Power Supply:

Class I - Single Phase
110-120 Volts, 60 Cycle, 20 Amps
220-230 Volts, 50 Cycle, 15 Amps

Dimensions:

Width - 55-1/4"
Height - 15-1/2"
Length - 38-3/4"
Weight - 265 pounds

C. Care and Safety Procedures

This machine is manufactured of the highest quality materials, but keep in mind that this is a sensitive piece of equipment. Care should be taken to see that it is not dropped, knocked around, or handled roughly.

Doing so may damage the programmable computer, its components, the conditioner transfer system, the duster assembly, or the vacuum cleaning and squeegee system.

For care and safety reasons, follow these precautions:

- Avoid spilling any liquids or chemicals inside of the machine.
- Do not operate the machine with an extension cord or power cord other than the one provided.
- Make sure that the power outlet used provides the correct voltage and amps. It must be a clean circuit with no other loads on it.
- Do not attempt to make any wiring modifications.
- Do not attempt to re-program the system software.
- Do not operate the machine in an upright position.
- Always empty the recovery tank before standing the machine up and transporting it. Failure to empty the tank will cause the dirty cleaner to either spill out through the vacuum motor or out of the squeegee when going over ramps. Then the next time the machine is started, it will blow cleaner out of the vacuum exhaust.

Not following the above recommendations may cause damage to the machine, its computer, persons operating it, or void the warranty.

Persons assigned the responsibility of operating this equipment should be trained in its use by an authorized factory-trained Distributor.

D. Theory of Conditioning Operation

This machine uses several felt wicking pads to transfer conditioner from a small reservoir to the transfer roller. A motor-driven camshaft controls the position of these pads during operation.

When the pads are in contact with the transfer roller conditioner will be applied. When the cams rotate they will push the pads away from the roller and no more conditioner will be applied.

The felt wicking pads are located in a trough that can be upgraded to maintain a consistent level of conditioner (with the optional tank). A valve opens on the optional tank when the float switch indicates the level is low. This provides consistent conditioner application from lane to lane without the need to constantly re-fill the supply tank.

It is important to let the wicks completely saturate with conditioner by performing the priming procedure **BEFORE** operating the machine on the lane. Allow the machine to set about 10 minutes in the operating position so the wicks can saturate and the trough can fill properly.

The type of conditioner will greatly affect the amount of output from the machine. However, there are three drive speeds available when conditioning to help control the flow of conditioner. To buff more conditioner on the lane the machine should travel at a slower speed.

Before transporting the machine after conditioning lanes, allow the trough to drain back into the tank. Allow it to drain completely **BEFORE** moving the machine up or down any ramps. Wait a couple of minutes with the machine in the transport position to ensure the trough is empty.

SECTION II - Machine Description

A. Rear; Center; Front; Right; & Left Side

With the machine setting on the approach in a position ready to be operated on the first lane, the following descriptions will be used:

- **CONDITIONING (REAR) END:** The CONDITIONING or REAR END shall be the end of the machine closest to the operator and nearest the approach, where the buffing brush is located.

- **CENTER COMPARTMENT:** The CENTER COMPARTMENT houses the electrical components and is located between the CONDITIONING END and the CLEANING END. Two partitions make up the compartment:
 - the vacuum and brush lift motor section (on the right);
 - the buffer motor section (on the left side)

- **CLEANING (FRONT) END:** The CLEANING or FRONT END shall be the end nearest to the pins, where the recovery tank and the Duster Assembly are located. This section also contains the PLC, fuses, and a relay bank.

- **RIGHT SIDE:** The RIGHT SIDE is the side to the right of the operator as he faces the pins. This is also the ten-pin side.

- **LEFT SIDE:** The LEFT SIDE is the side opposite the right, to the left of the operator as he faces the pins (seven-pin side).

B. Keypad

Mounted under the lid of the Conditioning end is the computer keypad. This keypad is used to enter all programming information. The keypad consists of 7 input keys and a four-line Liquid Crystal Display (LCD) where the menu items and prompts appear.

- **MENU/LEFT ARROW:** This key allows the operator to scroll back through the menu screens if an arrow is present on the left side of the display.
- **MENU/RIGHT ARROW:** This key allows the operator to scroll forward through the menu screens if an arrow is present on the right side of the display.
- **ESCAPE:** Use this key to return to the main menu.
- **UP ARROW:** Use of this key will increment or increase numbers needed in certain menu prompts. Holding the key down will make the numbers increase faster.
- **DOWN ARROW:** Use of this key will decrement or decrease numbers needed in certain menu prompts. Holding the key down will make the numbers decrease faster.
- **MOD:** This key is used to select which value to change in various menu screens. The key is also used to turn outputs ON and OFF in the Test Output menu.
- **ENTER:** This key is used to accept any changes that are made in the various menu screens. This key is also used to advance through any sub-menus and to advance to the "Day" setting in the clock menu.

C. Conditioning (Rear) End Components

Located on the Conditioning end of the machine are the following components:

- **DISTANCE WHEELS:** Located on the inside rear wall of the conditioning end are the lane distance wheels. These wheels measure the distance the machine travels down the lane in increments of one inch. This is done by counts stored in the PLC from the proximity sensor or Lane Distance Sensor (LDS) mounted on the center pillow block.
- **CONDITIONER SUPPLY TANK (OPTIONAL):** An optional tanks is available and can be mounted on the rear wall of the conditioning end compartment. The tank has a filter, a vent valve, a return vent line, and a wick trough. The capacity is 0.63 gallons or 2400 milliliters.
- **TANK VALVE (OPTIONAL):** When the optional tank is installed, this solenoid valve is mounted between the conditioner supply tank and the trough of the conditioner tank. This valve controls the amount of conditioner that flows into the tank trough when it is re-filled. During operation, this valve opens to maintain a consistent amount of conditioner for the wicking pads.
- **FELT WICKING PADS:** Mounted in the trough of the conditioner tank are six (or eight, depending on machine set-up) felt wicking pads. The sizes of these pads can be adjusted (in the six pad set-up) to create different shots on the lane. The 7" and 3" pads can be swapped on the outsides of the camshaft. Additional roll pin holes (in the camshaft) are provided to facilitate the change. The pads absorb conditioner from the tank and transfer it to the stainless steel roller.
- **TRANSFER ROLLER:** Mounted in front of the wicking pads is the conditioner transfer roller. This stainless steel roller is chain driven and transfers conditioner onto the buffing brush.
- **BUFFER BRUSH:** Located in front of the transfer roller is the buffer brush assembly. The belt-driven brush removes conditioner from the transfer roller and places it onto the lane surface.

CROSSFIRE Operators Manual

- **CAMSHAFT:** Mounted above the wick trough is the wick pad camshaft. This camshaft controls the position of the individual wick pads. When a cam is not engaged, the pad should rest against the transfer roller. When the cam rotates, the pad should not touch the transfer roller. The cams are mounted using roll pins.
- **TRANSFER ROLLER DRIVE MOTOR:** Mounted on the right side plate, is the transfer roller drive motor. This motor drives the transfer roller during conditioning runs.
- **CLEANER SUPPLY TANK:** Mounted on the rear wall is the cleaner supply tank. The capacity of this tank is approximately 1-7/8 gallons; enough volume to completely clean in excess of 20 lanes. The tank is equipped with an internal filter. A vent valve prevents a vacuum inside the tank during operation.
- **CLEANER PUMP:** Mounted on the rear wall to the left of the cleaner supply tank, is the cleaner pump motor. This motor pumps the cleaning liquid from the supply tank through the spray jets and onto the lane surface. Check the fittings periodically for leaks. Located on the left side plate is a button to prime the pump, check the cleaner spray pattern, or apply more cleaner to the heads. Make sure the machine is at the foul line, or on the lane, before pressing this button.
- **START/INTERLOCK/RESUME BUTTON:** Located on the handle is the Start/Interlock/Resume button. This button is used to START the machine; STOP it any time during the conditioning run; or to RESUME operation after it has stopped for an error message or some other reason.

D. Center Compartment Components

The Center Compartment of the machine is divided into two sections. From left to right, they are the buffer motor section and the vacuum and brush lifting motor section.

- **BUFFER MOTOR:** Mounted on the left side plate is the buffer brush motor. This AC single-speed motor rotates the buffer brush on the lane.
- **TERMINAL BLOCK:** Mounted on the left side plate above the buffer motor is a set of terminal blocks. These junction blocks are used for the tach sensor and to connect the low voltage circuits.
- **VACUUM MOTOR:** Located on the right side is the vacuum motor. This motor is used with the squeegee assembly and recovery tank to vacuum the cleaner off the lane. A specially-designed chamber reduces the noise created by the vacuum. **This motor needs regular maintenance**, and is mounted by two 1/4-20 bolts for easy access.

NOTE: The lid can be taken off the machine to make it easier to remove the vacuum motor and perform necessary maintenance.

- **BRUSH LIFT CAM:** Located next to the vacuum motor, on the side plate, is the brush lifting cam and switches. The switches are mounted to a plate that allows them to be adjusted for proper operation and over-travel.
- **TERMINAL BLOCK ASSEMBLY:** Mounted on the inside of the right wall is a set of low voltage (24VDC) terminal blocks. These blocks are a junction for the handle.
- **EMERGENCY STOP BUTTON:** (On 230 Volt Machines Only)
Located in the right compartment is an emergency stop switch. This safety button will disconnect power to the drive components of the machine if there is an emergency. This button will have to be rotated to be reset and the start button will need to be pushed to resume operation.

CROSSFIRE Operators Manual

- **POWER CORD INLET:** Mounted on the left side wall is the power cord inlet. This inlet is grounded to the machine frame. Make sure to use the correct voltage and amperage when connecting the cord to the inlet.



HIGH VOLTAGE WARNING: Use caution with electrical components. Refer servicing to qualified personnel. Observe and follow all Warning and Safety Labels.

- center of the compartment is the recovery tank. This tank will hold over 20 lanes of used liquid without needing to be emptied. Empty the tank from the inlet side (connected to squeegee). Always empty the recovery tank when filling the cleaner tank. Also empty this tank before standing the machine up into the transport position.

Use care when removing tank to prevent spilling liquid in the machine. Do not drop the tank or handle it roughly as this may cause it to leak.

- **SQUEEGEE CAM & SWITCHES:** The position of the squeegee is controlled by two switches mounted on the inside of right side plate. A cam connected to the squeegee motor has an offset lobe that actuates the switches. The switch toward the top of the machine is the Squeegee Down Switch and the switch located toward the bottom of the machine is the Squeegee Up Switch. These switches are mounted in slots to allow for adjustment and they are protected behind a guard. Prevent moisture from contaminating this area.

E. Cleaning (Front) End Components

The following components are located under the lid on the cleaning end of the machine:

- **DUSTER UP SWITCH:** Located on each side wall is a microswitch. These switches, when actuated, tell the PLC that the cushion roller is in the UP position. Avoid getting liquid near these switches (and all electrical components).
- **DUSTER/CLEANING CLOTH ASSEMBLY:** Mounted inside and across the entire front end is the Duster Cleaning Cloth Assembly. Two motors, one located on each side, move the cloth from one core to the next. The gear motor on the left side is called the **UNWIND MOTOR**. When operated, it will let out new cloth from the supply roll. The gear motor on the right side is the **WIND-UP MOTOR**. When operated, it will wind up the used, dirty cloth on the take-up roller.

The duster uses gravity to clean the lane. The cushion roller pivots and contacts the lane surface when cloth is unwound. This makes the cloth contour to the lane surface for optimum cleaning. At the end of the lane, just before the end of travel, the duster winds up dirty cloth and lifts the cushion roller off the lane. The cloth remains wound up during the return travel to the foul line.

For best results, use **Kegel "Select"** (153-0047EZ) cloth. The machine will use approximately 1-1/2" of cloth per lane.

- **SPRAY JET ASSEMBLIES:** Mounted to the front wall are three spray jet assemblies. These assemblies can be angled up or down, and left or right, to adjust spray coverage to the entire lane. Mounted with the spray tip is a combination check valve/filter. The tip in the center is a #8003 and the tips on the outside are #1501. These provide cleaner coverage across the entire lane.

CROSSFIRE Operators Manual

- **VACUUM EXHAUST PLATE:** The area where the vacuum exhaust is located is covered with felt in case any moisture blows through the motor. Use a soft rag to absorb any moisture that may collect in this area.

- **LIFTING HANDLE:** There are two lifting handles mounted on the front panel for lifting and placing the machine on the approach. When possible, have two people set the machine down and lift it into the transport position.

- **MOMENTARY WHEELS:** Mounted on the front outside wall are two small wheels. These wheels come in contact with the lane momentarily as the machine enters and exits at the foul line.

- **CONTROL PLATE ASSEMBLY:** The control plate assembly can be removed from the machine for maintenance by unplugging the wire connectors and removing four screws. Located on top of the control plate are the following components:
 - Buffer Motor Contactor;
 - Programmable Logic Controller;
 - PLC Output Expansion Module;
 - CR1 Vacuum Motor Relay (LY2);
 - CR2 Water Pump Relay (LY2);
 - Brake Resistor;
 - CR3 Reverse Drive Relay (LY3);
 - CR4 Forward Drive Relay (LY3);
 - Circuit Breaker for Power;
 - Component Fuses.

Located on bottom of the control plate is the following component:

- Terminal Block Assembly.
-
- **BUFFER MOTOR CONTACTOR:** Mounted to the right of the PLC is the buffer motor contactor. This provides AC power to the buffer motor when the PLC relay engages the coil. A din rail secures the contactor to the plate.

 - **PROGRAMMABLE LOGIC CONTROLLER:** The PLC (also called PC) is also mounted on the din rail. The terminal strip is removable if a replacement is necessary. Use care to prevent damage to the Controller.

CROSSFIRE Operators Manual

WARNING: The PLC contains a Lithium battery. When it is replaced, the old battery should be discarded in accordance with local regulations.

- **PLC EXPANSION MODULE:** This module adds 8 outputs when connected to the PLC. This component is also mounted on a din rail.
- **CONTROL RELAY 1:** This relay controls the operation of the vacuum motor. It is an LY2 type relay.
- **CONTROL RELAY 2:** This relay controls the operation of the water pump. It is an LY2 type relay.
- **BRAKE RESISTOR:** Mounted to CR#3 and CR#4 is the Brake Resistor. This resistor stops the drive motor when the drive motor relays are turned off.
- **CONTROL RELAY 3:** This relay controls the reverse operation of the drive motor. It is an LY3 type relay.
- **CONTROL RELAY 4:** This relay controls the forward operation of the drive motor. It is an LY3 type relay.
- **DRIVE MOTOR SPEED RELAYS AND ADJUSTING POTS:** The speed adjusting pots are accessed through the top of the control plate. The relays and trimpots are mounted to the bottom side.

Low speed comes on when either the forward or the reverse LY-type relay is on. The small speed relays (on the printed circuit board) are used to adjust the three different drive speeds. The trimpots, and their inches per second (IPS) speed ranges, go in order from left to right as follows:

- 09-10 IPS (turn clockwise to increase);
- 19-20 IPS (turn clockwise to increase);
- 29-30 IPS (turn clockwise to increase).

NOTE: These are the factory speed settings and they can be set differently to modify conditioner flow rates, if necessary.

CROSSFIRE Operators Manual

- **PROTECTIVE DEVICES:** Mounted on the PLC plate are several fuses and one circuit breaker. These components protect the operator and machine in the event of a current overload. The following is a list of the components:
 - **Main Circuit Breaker:** The circuits for the entire machine are protected with a circuit breaker. It is rated at 15A on a 115V model, and at 10A on a 230V model.
 - **PLC Power Fuse:** The PLC power supply is protected by a single slow blow fuse. It is rated at 1A on both 115V and 230V machines.
 - **PLC Common Fuse:** The PLC Outputs are protected by a single slow blow fuse. It is rated at 7.5A on a 115V model, and at 4A on a 230V model.
 - **Drive Motor Fuse:** The drive motor control board is protected by 2 slow blow fuses, one for L1 and one for L2. These are ceramic-type fuses rated at 4A.
 - **Brush Lift Motor:** The brush lift motor is protected with a slow blow fuse. It is rated at 2.5A on a 115V model, and at 1.6A on a 230V model.
 - **Squeegee Motor:** The squeegee motor is protected with a slow blow fuse. It is rated at 2.5A on a 115V model, and at 1.6A on a 230V model.
 - **Duster Windup Motor:** The duster windup motor is protected with a slow blow fuse. It is rated at 2.5A on a 115V model, and at 1.6A on a 230V model.
 - **Vacuum Fuse/Circuit Breaker:** The vacuum motor is protected with a slow blow fuse or a circuit breaker. The 115V model uses a fuse rated at 10A; the 230V model uses a circuit breaker rated at 8A.
 - **Cam Index Motor:** The index motor is protected with a slow blow fuse. It is rated at 2.5A on a 115V model, and at 1.6A on a 230V model.

CROSSFIRE Operators Manual

- **Transfer Roller Motor Fuse:** The transfer roller motor is protected with a slow blow fuse. It is rated at 2.5A on a 115V model, and at 1.6A on a 230V model.

- **Duster Unwind Motor:** The PLC duster unwind motor is protected with a slow blow fuse. This fuse is rated at 2.5A on a 115V model, and at 1.6A on a 230V model.

- **Cleaner Pump Fuse:** The cleaner pump is protected with a slow blow fuse. It is rated at 0.75A on a 115V model, and at 315mA on a 230V model.

Other protective measures include the following:

- **PLC Program:** The program also acts as a protective device on certain motors. These motors "time out" or have built in monitoring that trips an error message and stops operation. This will prevent the motors from overheating in the event of a locked rotor condition. The following motors are protected with the PLC Program: Brush Lifting Motor; Squeegee Motor; and the Duster Unwind and Wind-Up Motors.

- **Buffer Motor:** A fuse is not required for the AC motor, it has an automatic thermal overload breaker. A button must be pressed on the back of the AC motor to reset the overload trip circuit.

WARNING: Make sure no power is applied to the machine when re-setting the overload breaker (so the motor won't start unexpectedly).

The following components are found underneath the control plate in the center compartment:

- **DRIVE MOTOR PRINTED CIRCUIT BOARD:** Mounted on the bottom side of the control plate is a printed circuit board with relays and trim pots. This board controls the DC voltage to regulate the drive motor speeds.

CROSSFIRE Operators Manual

- **TERMINAL BLOCK ASSEMBLY:** Mounted on the bottom of the control plate are the main terminal blocks for the machine. The plate lifts out of the machine by removing the four mounting screws to allow access to this wiring when trouble-shooting a problem.
- **DRIVE MOTOR:** Mounted under the control plate is the DC drive motor. It turns the drive shaft and the tachometer actuating disk. This motor is mounted on slots to allow the chain tension to be adjusted.
- **DRIVE MOTOR SPEED CONTROL BOARD:** Mounted to the inside wall of the front compartment is the drive motor speed control board. The board converts AC voltage into DC voltage for the drive motor. Do not adjust the trim pots on the board unless instructed to do so by the Kegel Technical Support staff.
- **EMI FILTER:** (On 230 Volt Machines Only) Mounted below the control plate is an EMI filter. The speed control board must be filtered to reduce line conducted and radiated emissions. This filter must be connected properly to ensure compliance with Electromagnetic Compatibility Directives (CE Mark).
- **EMI FILTER:** (On 230 Volt Machines Only) Mounted below the control plate is a large EMI filter. The electrical circuits of the entire machine are filtered to reduce line conducted and radiated emissions. This filter must be connected properly to ensure compliance with Electromagnetic Compatibility Directives (CE Mark).
- **EMI FERRITE:** (On 230 Volt Machines Only) The 24V DC circuit is filtered at the output of the PLC Power Supply. A ferrite is clamped to the Brown and Yellow wires to reduce line conducted emissions. This component is required to comply with CE Directives.

F. Bottom Side Components

Located on the bottom or underneath the machine are the following components:

- **DRIVE SHAFT:** Located toward the center of the bottom is the lane drive shaft. This shaft is powered by the drive motor to move the machine forward or reverse on the lane.
- **DRIVE WHEELS:** Mounted on the lane drive shaft are the two drive wheels. These wheels rotate under power from the drive motor to move the machine on the lane.
- **SQUEEGEE ASSEMBLY:** Mounted near the front of the machine is the squeegee assembly. This assembly vacuums the cleaner and conditioner off of the lane during lane cleaning. The unique mount for the squeegee allows the tilt or pitch to be adjusted. There are also independent height adjustments for the left and right side. The squeegee pitch is adjusted using the turnbuckles and link mounted to the squeegee position cam.
- **GUIDE ROLLERS:** Mounted on the outside walls are four spring-loaded guide rollers. These tapered rollers ride along the edge of the lane to keep the machine straight and square as it travels on the lane surface.
- **SKID PLATES:** Two small UHMW pieces are mounted to the floor of the machine. These will help prevent damage if the machine travels too far forward and ends up in the pit.

G. Right Side Components

The following components are located on the right outside wall of the machine:

- **DUSTER WIND-UP MOTOR:** Mounted toward the front of the machine is the duster wind-up motor. When this brake motor operates, it winds-up used cloth and lifts the cushion roller from the lane surface.
- **TRANSPORT HANDLE:** A handle is provided to make the machine easier to move while in the transport position.
- **LANE-TO-LANE CASTERS:** Located on the outside of the frame are two lane to lane casters that support machine as it is moved on the approach from one lane to the next.
- **SQUEEGEE MOTOR:** Mounted to the right side plate is the mechanical brake motor which controls the up and down movement of the squeegee. A cam is mounted on the shaft to hold the adjusting linkage for the squeegee pitch.
NOTE: Do not make the pitch linkage too short as this may cause the motor to bind during travel.
- **SQUEEGEE ADJUSTMENT:** The squeegee height can be adjusted by loosening the pivot mounts located on the side plates and setting them to the desired height. There is a separate adjustment for the left and right sides. Make sure the squeegee stays relatively level in the machine.
- **TRANSFER CHAIN:** Mounted on the right side is the transfer roller drive chain and sprockets.
- **HANDLE CATCH:** A small piece of UHMW is mounted to the top of the side wall to hold the handle in place during transport.

H. Left Side Components

The following components are located on the left outside wall of the machine:

- **DUSTER UNWIND MOTOR:** Mounted toward the front of the machine is the duster unwind motor. This brake motor operates to unwind new cloth and lower the cushion roller onto the lane surface.
- **SQUEEGEE ADJUSTMENT:** The squeegee height can be adjusted by loosening the pivot mount and relocating it to the desired height. There is a separate adjustment for the left and right sides.
- **BUFFER BELT:** The buffer belt is located on the left side. It is routed around an idler pulley. Check the tension of the belt periodically to ensure proper operation.
- **TRANSPORT HANDLE:** A handle is provided to make the machine easier to move while in the transport position.
- **HANDLE CATCH:** A small piece of UHMW is mounted to the top of the side wall to hold the handle in place during transport.
- **BUFFER BRUSH LIFT MOTOR:** Mounted on the right side of the machine is the buffer brush lift motor. This motor lifts the buffer brush off the lane. The brush needs to be lifted at times where conditioner is not being applied (i.e. from the end of the pattern through the pindeck during all cleaning cycles). The brush parks in the down position and should be stored with the brush down to prevent the transfer roller from spreading the fibers too much.

CROSSFIRE Operators Manual

- **PRIME PUMP BUTTON:** Located next to the handle pivot mount is the cleaner prime pump button. This button will activate the cleaner pump in any mode of operation. Make sure the machine is positioned properly before applying cleaner.
- **LANE-TO-LANE CASTERS:** Located on the outside of the frame are the lane to lane casters. These casters support the machine as it is moved on the approach from one lane to the next.

SECTION III - Pre-Installation

Preparation of the Bowling Lanes

Prior to operating this equipment for the first time, it is highly recommended that a thorough inspection of the bowling lane and approach area take place.

All loose foul lights, divisions, cappings and adapter blocks and channels should be tightened, repaired or replaced.

High channels will lift one side of the machine and cause errors. Loose capping screws, loose gutters, and missing capping sections may cause damage to the power cord.

SECTION IV - Operating Instructions

A. Filling the Conditioner Tank

Fill the conditioner tank prior to operating on the first lane. Do not transport the machine over steep ramps when this tank is full. To fill the conditioner tank, the machine should be in the down position on a level surface. Remove the cap located on the top of the fill tube.

Insert the funnel assembly provided with the machine. Fill the tank until the oil level is entering the vent tube. Pour the conditioner slowly and do not overfill the tank.

Any overflow can drain down onto the lane distance proximity sensor or the buffer brush, which will cause an excess amount of conditioner to be applied to the lane in that area for several lanes. You should place an oil rag beneath the fill tube to prevent this from happening.

When finished, be sure to remember to replace the cap. Failure to do so could cause a major mess if the machine is lifted to the transport position.

The tank valve (optional) will open automatically during operation to keep the wick trough full of conditioner. This should prevent inconsistencies in conditioner output due to dropping oil levels in the tank. However, use of a USBC Approved Take-Up Device and Lane Reader is recommended to determine if and when conditions are changing.

B. Filling of Cleaner Supply Tank

To fill the Cleaner Supply Tank, the machine should be in the down or operating position. Prepare an appropriate mixture of cleaner and water.

Open the splash guard and place a rag beneath the tank. Open the tank cap and place an absorbent rag around the base of the funnel to prevent cleaner foam from overflowing out of the tank. Pour the mixture into the Supply Tank using the supplied funnel until the level is about 1/2" below the top of the tank. This will prevent an air pocket from forming and blocking the fluid flowing from the funnel.

NOTE: Always use the funnel supplied with the machine. This funnel has a plastic filter screen. This screen filters out all debris and trash to prevent it from contaminating the supply tank and cleaning system. Not using a funnel with a filter may cause the tank's internal filter to become clogged frequently. It can also cause premature failure of the cleaner pump. At the very least, this will reduce the cleaner output of the spraying system and result in inadequate stripping. This may lead to customer complaints, ball calls, and an excess of out-of-range pins. When necessary, the supply tank can be removed for cleaning.

Do not spill cleaner on the electrical components. Spills may cause a "short", which may send a false signal to the PLC causing improper operation. A wet switch may also produce a dim LED light on the PLC.

Any spills or drops of cleaner onto the approach should be wiped up immediately! Any spills on the machine can stain the paint and make the machine ugly. Ugly machines do not run as well as clean, sharp, and highly maintained machines.

NOTE: If the lanes are going to be cleaned make sure the Cleaner Supply Tank is filled, the Recovery Tank is empty, and an adequate supply of Lane Cleaning Cloth is installed before beginning operation. Always empty the recovery tank when filling the supply tank.

C. Turning the Unit On

Carefully set the machine in the operating position on the approach. It should be completely on the approach, with the cleaning end being approximately 6 inches behind the foul line.

Connect the power cord into a suitable outlet. MAKE SURE THAT THE OUTLET IS SUPPLYING THE CORRECT VOLTAGE AND AMP RATING (see Section 1-1). Connecting the power cord into an outlet located toward the center lanes of the establishment will allow more lanes to be cleaned and/or conditioned without changing outlets. Then plug the twistlock connector plug into the machine.

The power cord supplied with the machine will be long enough to clean several lanes without the need to change outlets. (To accomplish cleaning the maximum number of lanes, the cord should be plugged into an outlet at approximately Lane 6. This will allow enough slack in the cord to place it out of the machine's path as it cleans/conditions lanes 1-12.)

When power is applied to the machine the menu screen on the keypad will illuminate. The machine is now ready to run.

If the machine does not appear to have any power after it has been plugged in, check the E-STOP switch to make sure it hasn't been accidentally pressed. Rotate the red button to reset this switch. Power will resume immediately.

Note: E-STOP switches are on 230 volt machines only.

D. Keypad Display

The keypad display is a four line LCD (Liquid Crystal Display). During operation and selection of programs, various prompts, which are simply questions or data requests, will appear in the display, along with possibly some numbers.

The prompts will request the operator to input or change data or information within the selecting menu. The numbers will display cleaning and/or conditioning program numbers, distances (feet or "counts"), and various settings. What the prompts and numbers mean for each menu is explained under each menu heading in this section.

In some menus there will be only one number in the lower right hand corner. This will be the value of the menu prompt displayed. By using the UP ARROW or DOWN ARROW you can change the value. **The value is set when the ENTER key is pressed.**

E. Operators Menu Selections

Operation of the machine is controlled by a series of programs located within the memory of the programmable computer. These programs and settings may be changed or modified by following a simple sequence of prompts within the available menus displayed on the keypad. This section will lead the operator step-by-step through menus and prompts.

To make this section easily understandable, the operator should be familiar with the keypad as detailed in Section II of this manual.

1. Run Mode

When the machine is powered up the RUN SCREEN will appear. This is the main starting menu:

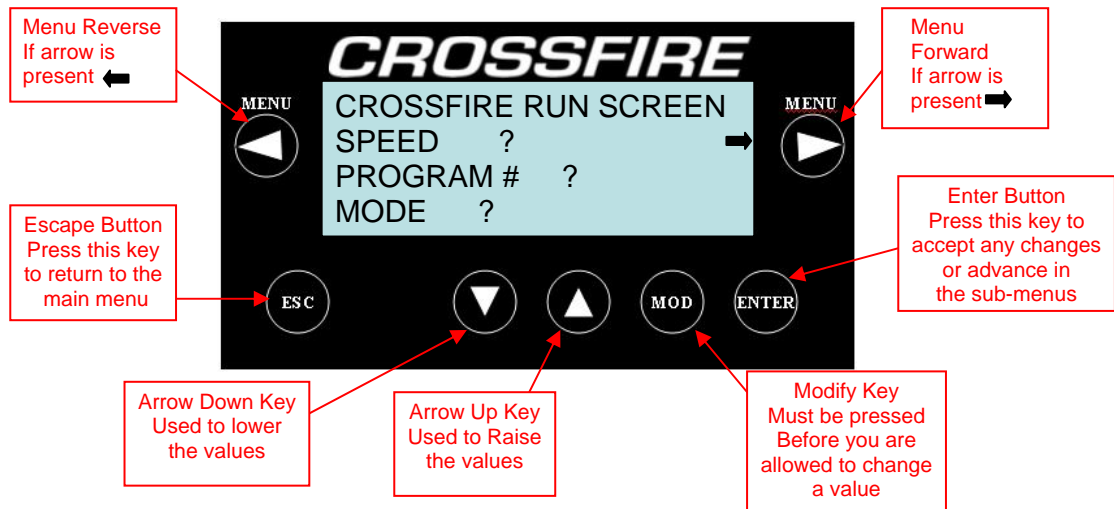

SPEED - Displays the current speed as the machine travels forward and reverse

PROGRAM # - Displays the current program that will be running

MODE - Displays the current position of the selector switch

The Crossfire is always ready to run when this prompt is displayed. By pressing the handle button or the UP ARROW the machine sequence will start.

Pressing the button the first time will lower the squeegee and unwind duster cloth. The vacuum will also come on (unless the machine is set to oil only).

CROSSFIRE Operators Manual

NOTE: If the machine is in **OIL ONLY** mode it is possible to turn the duster off, therefore nothing happens on the first button push when the duster is turned off.

Push the machine into the lane. At this time, if the machine is programmed to clean, you may prime the cleaner pump by pressing the button located next to the left-side handle pivot mount (this must be done before the second push of the handle button).

Now press the start button a second time and the machine will begin operating. The speed of the machine will be displayed on the second line of the screen and the program number will change to show the total number of lanes that the machine has either cleaned and/or conditioned. The number on the lower right should be used to plan the scheduled maintenance at the recommended intervals.

2. Manual Reverse Menu

Press the **MENU/RIGHT ARROW** key until the following SCREEN appears:



To return the machine to the foul line, press the **START BUTTON** on the handle and hold it. The machine will return to the foul line at about 20 inches per second as long as the button is held down.

3. Program Override Menu

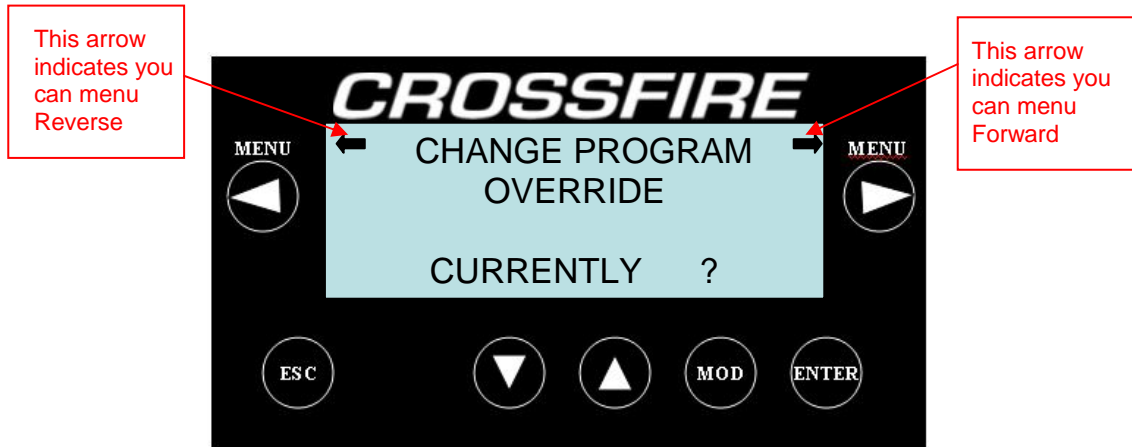

This screen allows you to override the 7 Day Planner and run a different program other than what is programmed to be running on that day. To change this number press the MOD key and then either the up or down arrow key. Once you have the program you want press the enter key.

4. System Upgrade Menu

Press the **MENU/RIGHT ARROW** key and the following screen will appear:

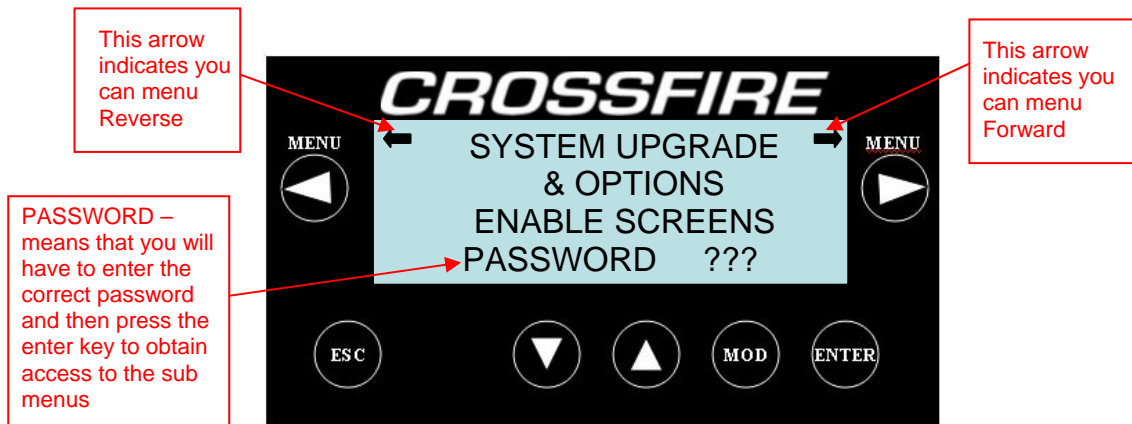

If you have installed one of the upgrades that are available for your machine, this is the menu where you will activate that upgrade. To enter this menu you will have to input the password that was provided to you by Technical Support.

CROSSFIRE Operators Manual

To continue within the menu, enter the password using the appropriate sequence of keys. First, you will need to press the MOD key. After pressing this key three digits will appear on the screen. Press the UP/Down arrow keys until the desired number appears in the first position. Press the RIGHT arrow key, the second digit will now be highlighted. Press the UP/DOWN arrow keys until the desired number appears in the second position. Press the RIGHT arrow key, the third digit will now be highlighted. Press the UP/DOWN arrow keys until the desired number appears in the third position. Now press the ENTER key to open the menu.

The following screen will appear once the correct password is entered:



This screen will display the current number of pads installed in the machine. To change this number, use the UP ARROW key. NOTE: If you did not install the wick pad upgrade, DO NOT change this number.

To continue within this menu, press the **ENTER** key and the following prompt will appear:

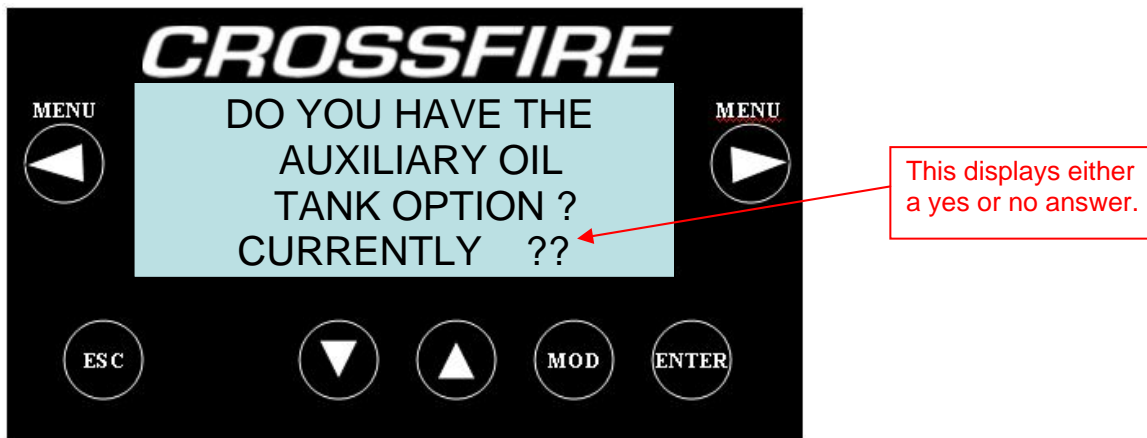

CROSSFIRE Operators Manual

This screen will display whether or not the Auxiliary oil tank is installed. To change this to YES or NO, use the UP ARROW key. NOTE: If you did not install the auxiliary oil tank upgrade, DO NOT change this screen.

To continue within this menu, press the **ENTER** key and the following prompt will appear:

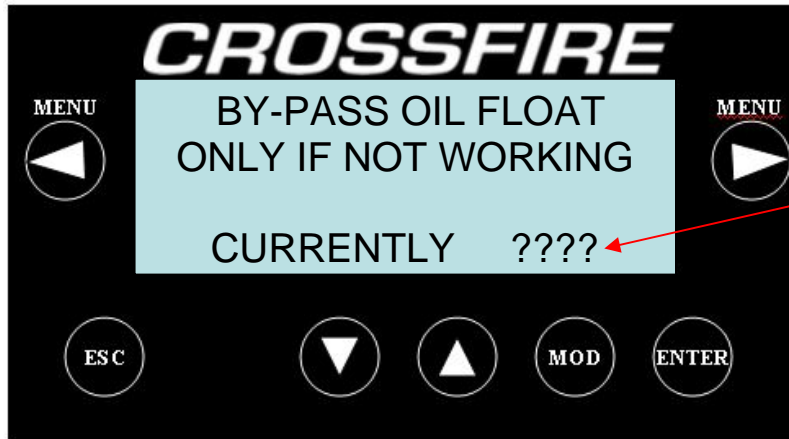

This displays either oil float is working fine or you have by-passed the float.

This screen will display whether or not the Oil Float Switch has been by-passed. This option is available if there is an error with the float switch. You can use this menu to by-pass the switch until the problem is fixed. To change this number, use the UP ARROW key. NOTE: If there is not a problem with the switch and you are not directed to use this option by Tech Support, leave the setting at "0".

Press the **ENTER** key to return to the main menu.

5. Change Program Menu

Four (4) factory-preset cleaning and/or conditioning patterns are stored in the computer's memory. These preset programs may be altered in the CHANGE PROGRAM menu. This menu cannot be accessed without entering the **Change Program Password**. The MOD key, the UP ARROW key, the RIGHT ARROW key, and the ENTER key are used to enter the password. (Refer to page 4-8 for detailed steps on how to enter the password)

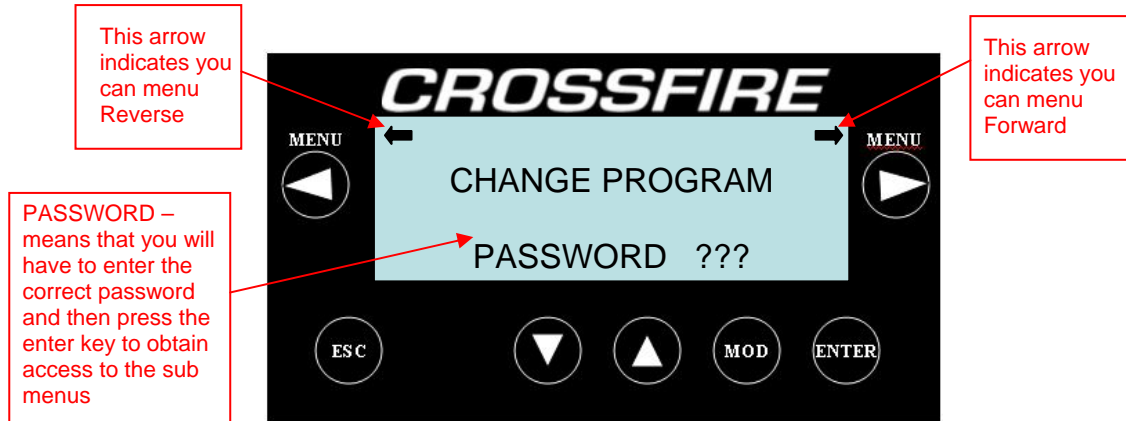

To see a sample graph and default settings for each of the patterns applied by the programs, please see Section VIII in this manual.

To continue within the menu, enter the password using the appropriate sequence of keys. After the password has been entered, the screen will change to show the following:

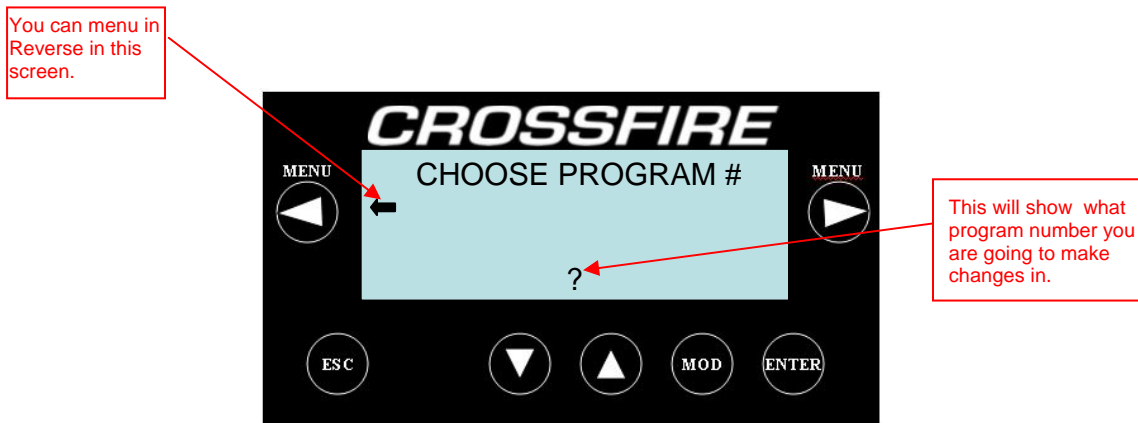

Press the **MOD** key, this will highlight the program number. Use the UP or DOWN arrow keys to scroll to the desired program number (1,2,3, or 4).

CROSSFIRE Operators Manual

Press the **ENTER** key and the following will appear:

You can menu in Reverse in this screen.

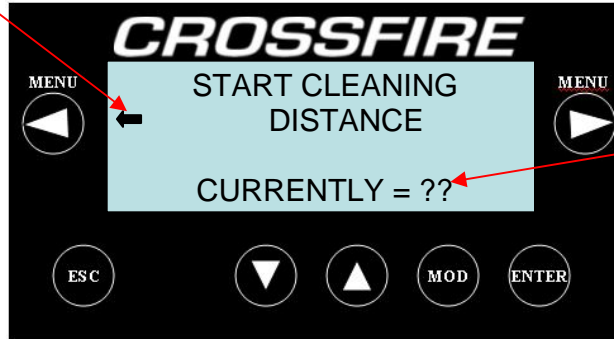

This displays the start distance for cleaning to start, by default this is set to zero.

This prompt is referring to the distance at which the machine starts applying cleaner to the lane. A setting of "0" means the machine starts its cleaning cycle at the beginning of the lane. This number can be any number between 0 and 60. Each increment would be one foot further down the lane that the cleaning cycle would start.

To change the value, press the **MOD** key. Once the digit is highlighted, use the **UP** or **DOWN ARROW** key to change the number to the desired amount.

If this number is correct, press **ENTER** and the following will appear:

You can menu in Reverse in this screen.

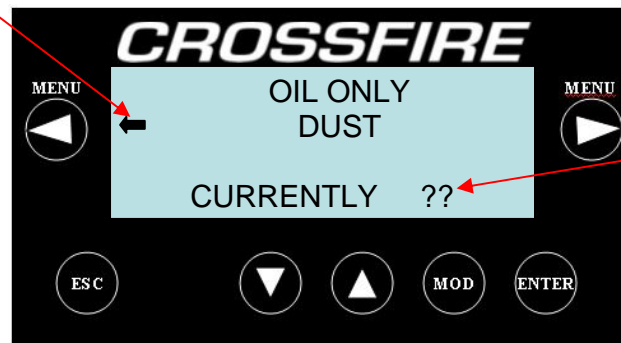

This displays the either yes or no to lower the duster in oil only, by default this is set to no.

If the text displayed on this screen is "NO", then the machine will not dust the lane in an "OIL ONLY" run. If the text is "YES", the machine will dust the lane in an "OIL ONLY" run. To change the setting, use the combination of keys that are described on page 4-8.

CROSSFIRE Operators Manual

Press **ENTER** and the following will appear:

You can menu in Reverse in this screen.

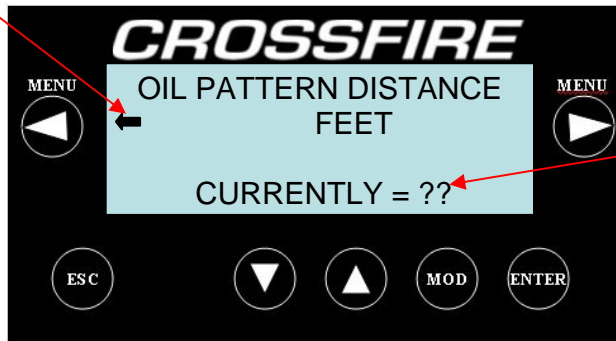

This displays the length of the oil pattern.

The number displayed will refer to the distance in feet down the lane at which oil will be applied to the lane (this distance is for the current program that is selected). To change this number use the sequence of keys that is described at the top of page 4-8 (the maximum number that this distance can be is 56, the minimum value is 0).

Press the **ENTER** key and the following will appear:

You can menu in Reverse in this screen.

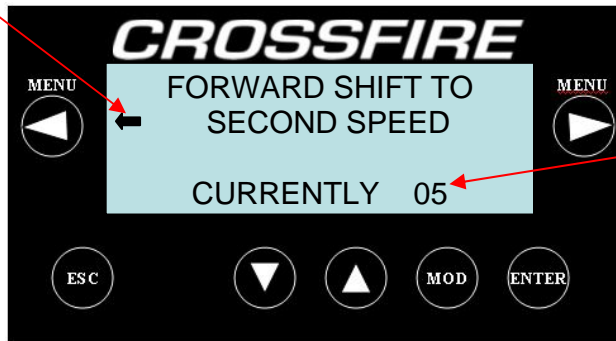

This displays the distance to shift up to second speed.

This prompt will display the distance down the lane where the Crossfire will shift from Low Speed to the Second Speed. This example shows the machine traveling 5 feet in low speed before shifting to second speed. To change this distance, use instructions at the top of page 4-10.

CROSSFIRE Operators Manual

Press the **ENTER** key and the following will appear:

You can menu in Reverse in this screen.

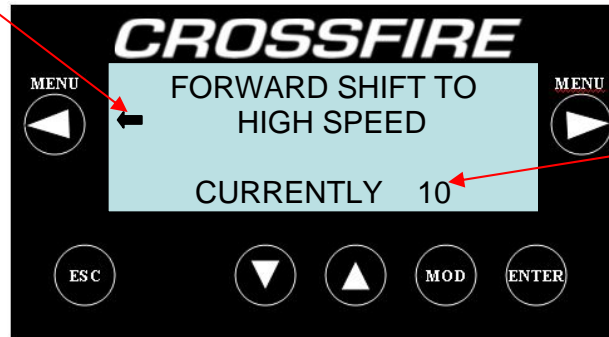

This displays the distance to shift up high speed.

This prompt will display the distance down the lane where the Crossfire will shift from Second Speed to High Speed. This example shows the machine traveling 10 feet in the second speed before shifting to high speed. To change this distance, use instructions at the top of page 4-8.

Press the **ENTER** key and the following will appear:

You can menu in Reverse in this screen.

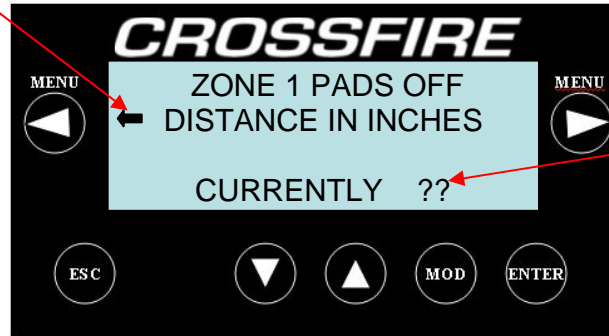

This displays the distance to turn off zone 1 pads

This is the distance from the foul line going forward that you have the Zone 1 or outside pads turn off. This setting is in inches. Once you have made your change or if the current setting is okay, press the enter key to advance to the next sub menu.

CROSSFIRE Operators Manual

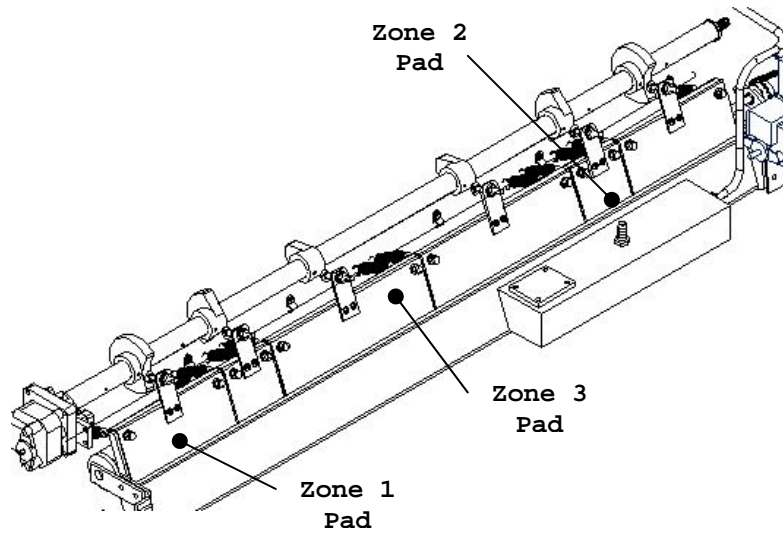

After pressing the **ENTER** key the following will appear:

You can menu in Reverse in this screen.

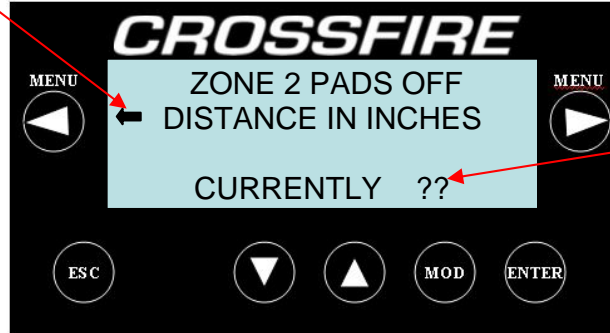

This displays the distance to turn off zone 2 pads

This is the distance from the foul line going forward that you have the Zone 2 pads turn off. This setting is in inches. Once you have made your change or if the current setting is okay, press the enter key to advance to the next sub menu.

CROSSFIRE Operators Manual

Press the **ENTER** key and the following will appear:

You can menu in Reverse in this screen.

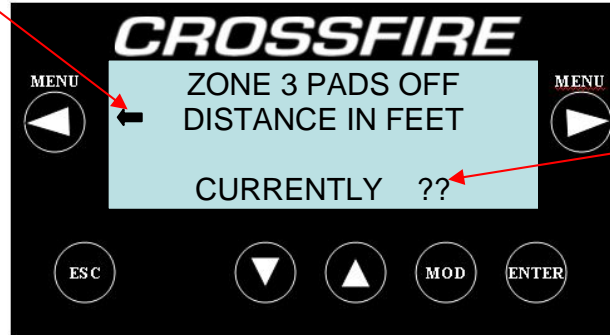

This displays the distance to turn off zone 3 pads

This is the distance from the foul line going forward that you have the Zone 3 pads turn off. This setting is in feet. Once you have made your change or if the current setting is okay, press the enter key to advance to the next sub menu.

Press the **ENTER** key and the following will appear:

You can menu in Reverse in this screen.

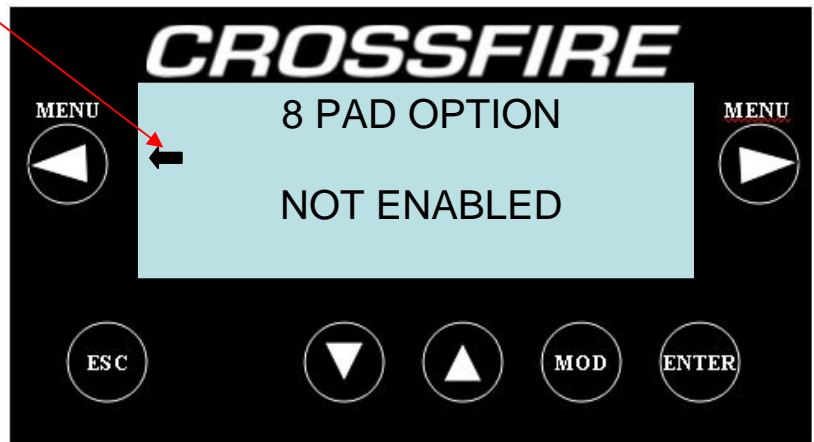

This prompt tells the operator that the machine is not set up with the 8 Pad option. The machine still has the factory installed 6 Pad set up.

CROSSFIRE Operators Manual

If the machine does have the 8 Pad upgrade installed, the following screen will appear:

You can menu in Reverse in this screen.



This displays the distance to turn off zone 4 pads

This is the distance from the foul line going forward that you have the Zone 4 pads turn off. This setting is in feet. Once you have made your change or if the current setting is okay, press the enter key to advance to the next sub menu.

Press the **ENTER** key and the following will appear:

You can menu in Reverse in this screen.

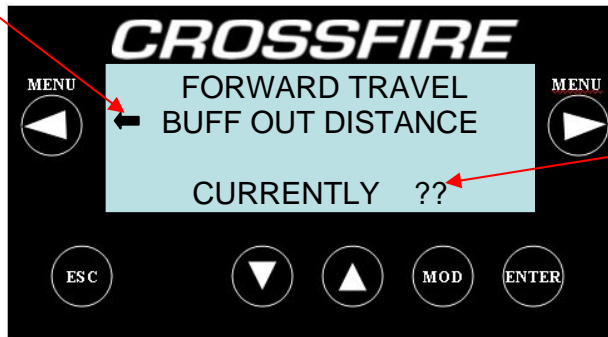

This displays the distance to start buff out.

This is the distance from the foul line going forward that you set the machine to start the buff out. When this distance is shorter than the oil pattern distance it will turn off the transfer roller at the specified distance. Once you have made your change or if the current setting is okay, press the enter key to advance to the next sub menu.

Press the **ENTER** key and the following will appear:

You can menu in Reverse in this screen.

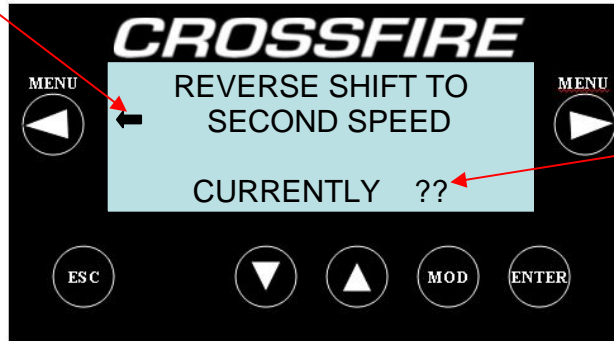

This displays the distance to shift down to second speed.

This is the distance from the foul line when traveling in reverse that you have the machine shift to second speed. Once you have made your change or if the current setting is okay, press the enter key to advance to the next sub menu.

Press the **ENTER** key and the following will appear:

You can menu in Reverse in this screen.

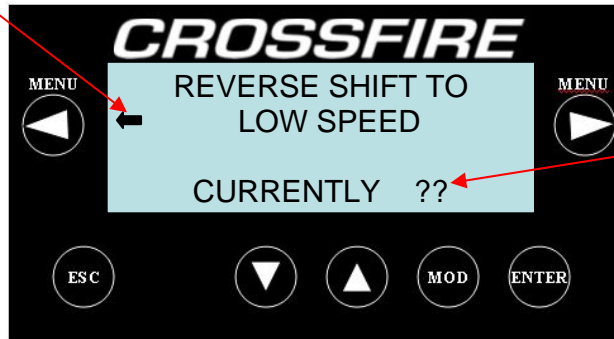

This displays the distance to shift down to low speed.

This is the distance from the foul line when traveling in reverse that you have the machine shift to low speed. Once you have made your change or if the current setting is okay, press the enter key to advance to the next sub menu.

CROSSFIRE Operators Manual

Press the **ENTER** key and the following will appear:

You can menu in Reverse in this screen.

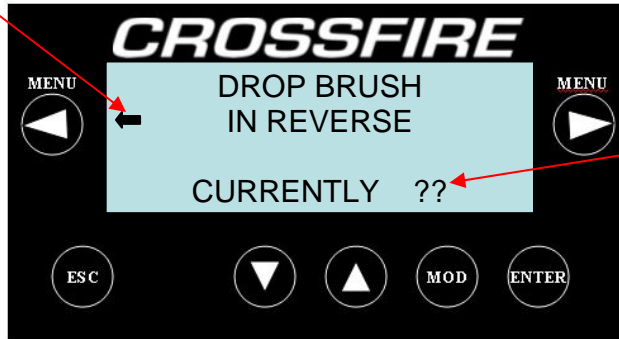

This displays the distance to drop the brush in reverse.

This is the distance from the foul line when traveling in reverse that you set the machine to drop the brush. Once you have made your change or if the current setting is okay, press the enter key to advance to the next sub menu.

Press the **ENTER** key and the following will appear:

You can menu in Reverse in this screen.



If the 8 pad option is not selected this screen will appear. Just press the enter key to continue to the next screen.

CROSSFIRE Operators Manual

Press the **ENTER** key and the following will appear:

You can menu in Reverse in this screen.

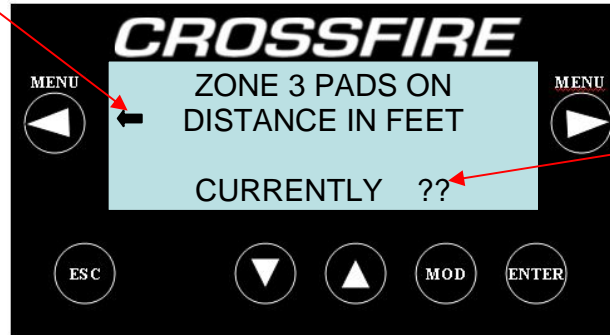

This displays the distance to turn on zone 3 pads

This is the distance from the foul line going in reverse that you have the Zone 3 pads turn on. This setting is in feet. Once you have made your change or if the current setting is okay, press the enter key to advance to the next sub menu.

Press the **ENTER** key and the following will appear:

You can menu in Reverse in this screen.

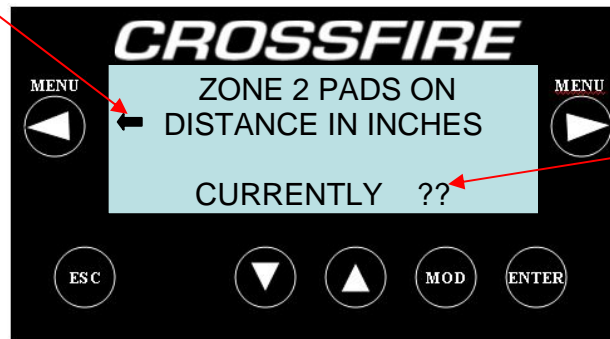

This displays the distance to turn on zone 2 pads

This is the distance from the foul line going in reverse that you have the Zone 2 pads turn on. This setting is in inches. Once you have made your change or if the current setting is okay, press the enter key to advance to the next sub menu.

CROSSFIRE Operators Manual

Press the **ENTER** key and the following will appear:

You can menu in Reverse in this screen.

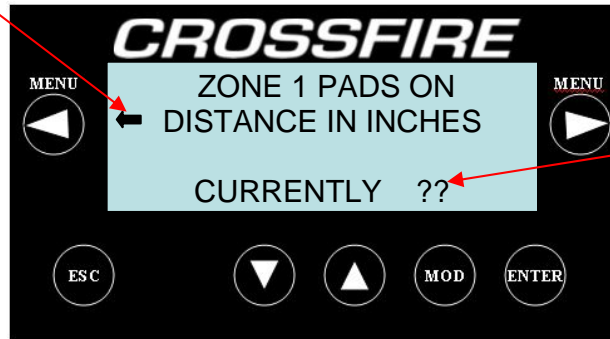

This displays the distance to turn on zone 1 pads

This is the distance from the foul line going in reverse that you have the Zone 1 pads turn on. This setting is in inches. Once you have made your change or if the current setting is okay, press the enter key to advance to the next sub menu.

Press the **ENTER** key and the following will appear:

You can menu in Reverse in this screen.

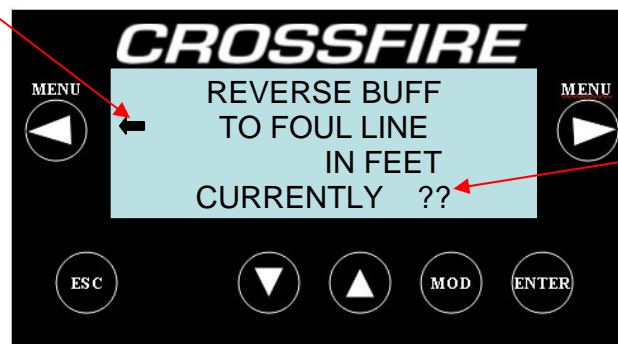

This displays the distance to buff to foul line in reverse

This is the distance from the foul line when traveling in reverse that you have the machine stop the transfer roller. Once you have made your change or if the current setting is okay, press the enter key to advance to the next sub menu.

CROSSFIRE Operators Manual

Press the **ENTER** key and the following will appear:



This screen asks you if you want to review all of change program screens. If you exit the change program area, you will return to the Change Program Main Screen.

6. System Control Cleaning Menus

This series of screens will be used to adjust various cleaning features in the machine's program.



This set of sub menus allow you to change important cleaning and travel information.

Press the **ENTER** key and the following will appear:



This is the current time that the cleaner pump stays on. Once you have made your change or if the current setting is okay, press the enter key to advance to the next sub menu.

CROSSFIRE Operators Manual

Press the **ENTER** key and the following will appear:

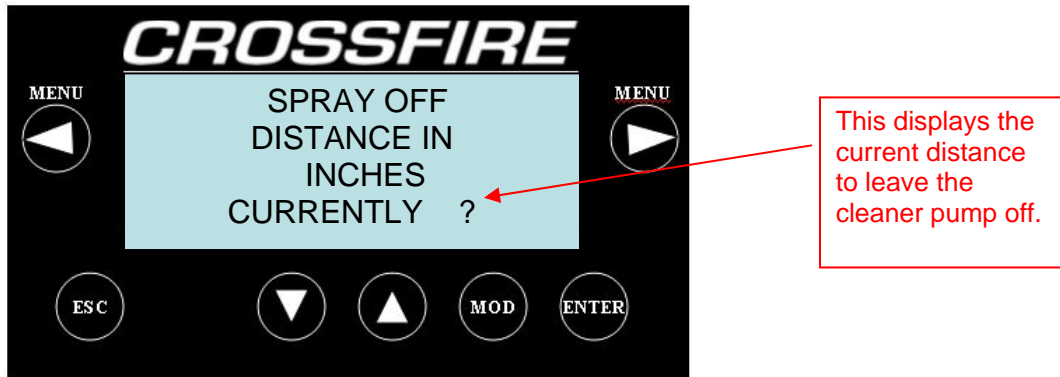

This is the distance that the machine travels before it allows the cleaner pump to spray again. Once you have made your change or if the current setting is okay, press the enter key to advance to the next sub menu.

Press the **ENTER** key and the following will appear:



This is the distance going forward that you want the last spray of cleaner on the lane before you reach the end of the lane. Once you have made your change or if the current setting is okay, press the enter key to advance to the next sub menu.

CROSSFIRE Operators Manual

Press the **ENTER** key and the following will appear:



This is a YES or NO question. By default it is set to NO. Under normal situations the normal cleaning is enough to clean the pin decks. In the case the pin decks are not getting cleaned you can answer YES to this question and the cleaner pump will spray one time on the pin deck. Once you choose your answer, press the enter key to advance to the next sub menu.

Press the **ENTER** key and the following will appear:

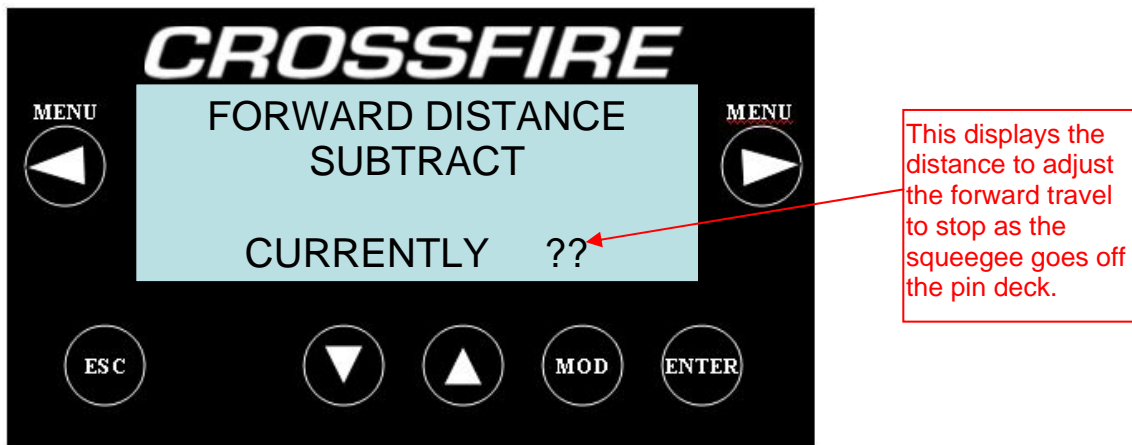

This distance compensates for various centers as the machine gets to the end of the pin deck. The smaller the number, the further the machine travels forward. Once you choose your answer, press the enter key to advance to the next sub menu.

Press the **ENTER** key and the following will appear:

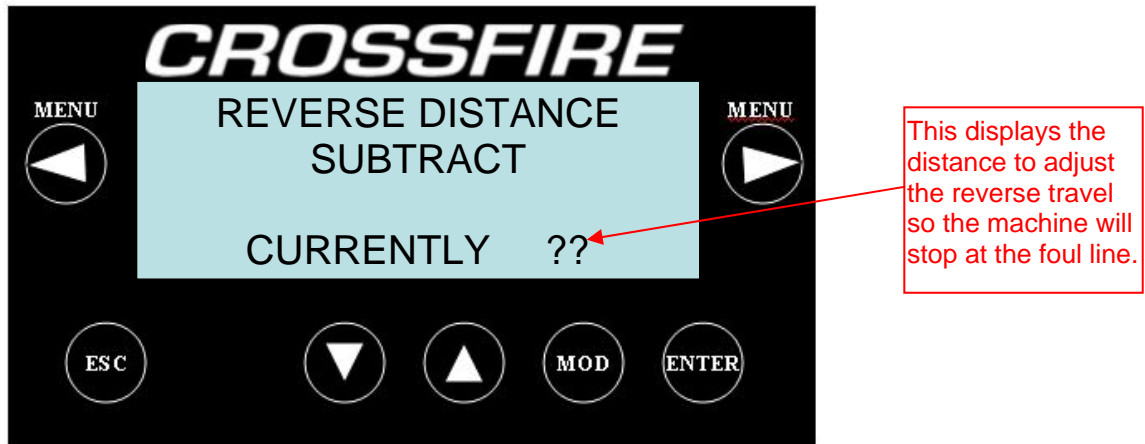

This distance compensates for the machine as it travels in reverse as the machine gets to the foul line. The smaller the number the further the machine travels in reverse. When you press the enter key you will return to the System Control Cleaning Main Screen.

7. System Control Duster Menus

These screens will be used to operate and reset the duster functions.

Press the **MENU** key until the following screen appears:



CROSSFIRE Operators Manual

Press the **ENTER** key, the following screen will appear:

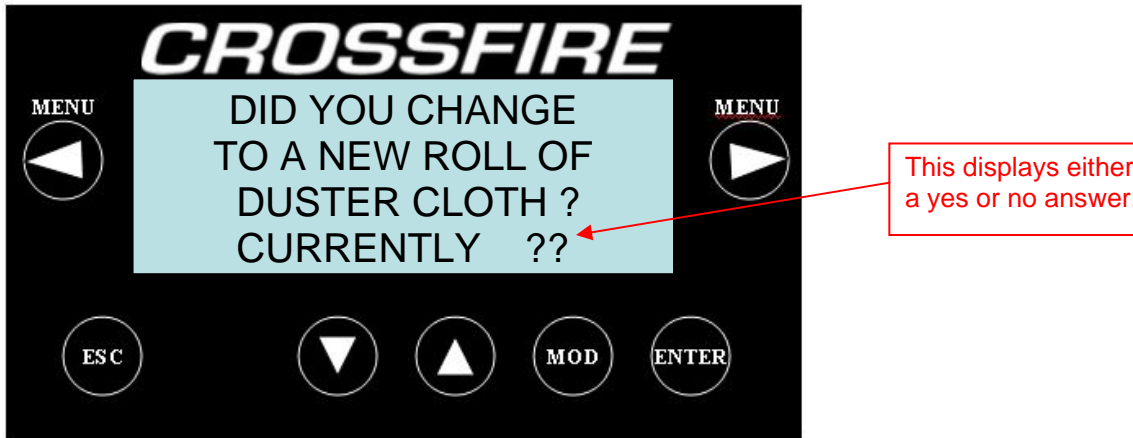

This asks if you changed to a new roll of duster cloth and if you answer YES it will change the duster unwind time to the system default. Once your answer is correct then press the enter key to advance to the next sub menu.

Press the **ENTER** key, the following screen will appear:

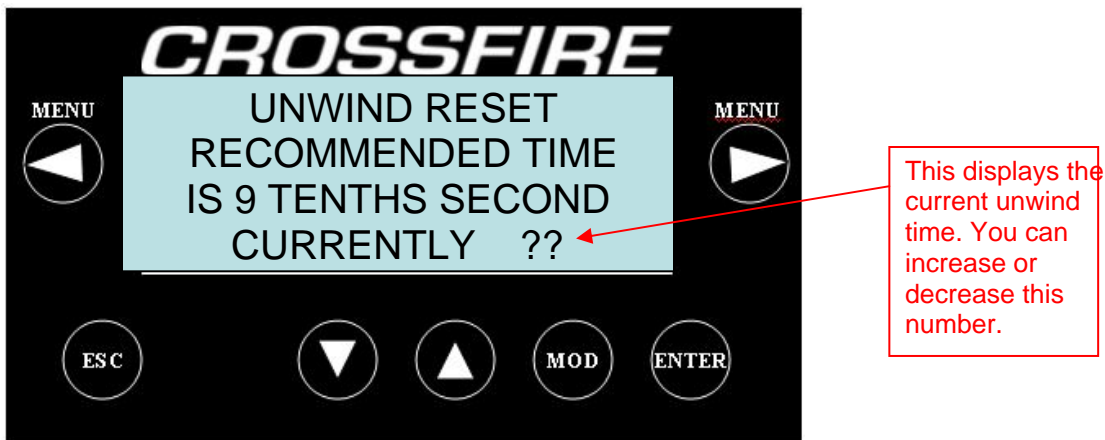

This displays the current unwind time. This number increases by one number every 35 lanes to compensate for the unwinding of the cloth. You can increase or decrease this value from this screen by using the up or down arrow. Once your answer is correct then press the enter key and you return to the System Control Dust Main Screen.

NOTE: *Resetting the DUSTER counter prior to the roll of cloth being empty could reduce the cleaning efficiency of the machine. The cushion roller must be allowed to drop far enough to contact the lane. In this menu it is possible to*

CROSSFIRE Operators Manual

correct the present unwind time if one of your pinchasers has presented you with this problem.

The unwind time varies from 11 for a fresh roll to 22 for an almost empty roll. If accidentally reset, use an educated guess on how much of the roll is already used and set your time accordingly.

EXAMPLE: If the roll is about half used, then set the time to 15.

This concludes the selections in the
SYSTEM CONTROL DUSTER menu.

8. Auto Program

Press the **MENU** key until the following screen appears:



This feature allows the machine to store specific conditioning programs to be used for each day of the week, within each time period of the day.

The "real time" clock in the machine's PLC keeps track of the time of day and will run the program selected for that specific time period. The time periods are not broken down by the hour, but rather are separated into two time categories, AM and PM.

For example, a conditioning program selected for Sunday AM means that operation of the machine any time between 12:01 AM and 12 Noon will apply that selected conditioner program.

To continue within this menu, press the **ENTER** key and the following prompt will appear:



CROSSFIRE Operators Manual

Use the UP ARROW to change the program number and the value will be set. The DOWN ARROW does not function in these menu screens, the program number will loop back around to 01 if the UP ARROW is pressed with program 04 showing.

Press the **ENTER** key and the PM time period for Sunday will appear. Advance to the rest of the days of the week and enter the program numbers that you wish to run.

A program can be entered for each of the following time periods:

MONDAY AM

MONDAY PM

TUESDAY AM

TUESDAY PM

WEDNESDAY AM

WEDNESDAY PM

THURSDAY AM

THURSDAY PM

FRIDAY AM

FRIDAY PM

SATURDAY AM

SATURDAY PM

SUNDAY AM

SUNDAY PM

NOTE: The machine will only run the program set for that day and time. If you wish to override a program, it will have to be changed in the appropriate day and time period.

This concludes the selections in the

7 DAY PROGRAM PLANNER menu.

Press **ENTER** to loop around to the start of the menu again.

9. Test Output

Press the **MENU** key until the following screen appears:

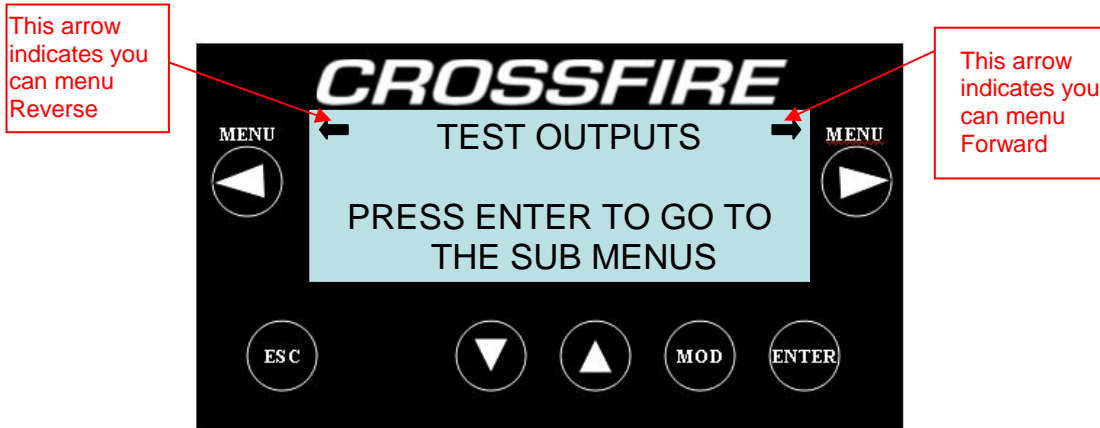

Press the **ENTER** key until the following screen appears:

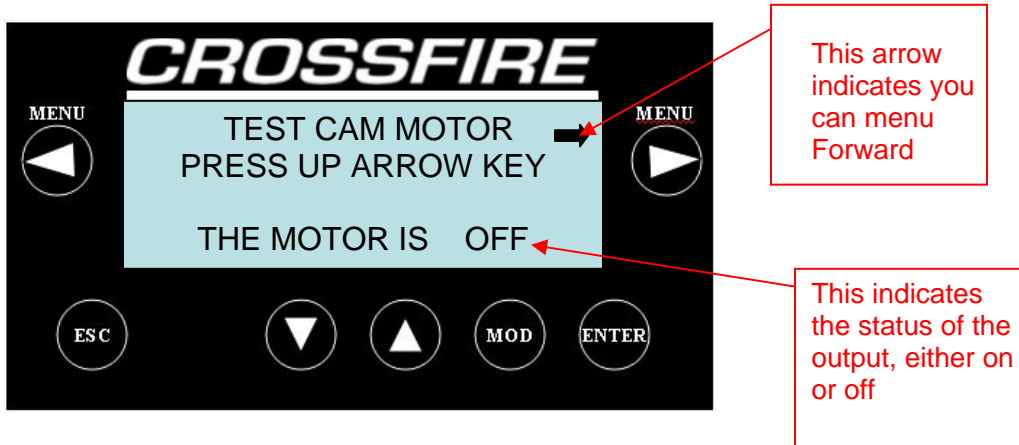

The prompt above shows that Cam Motor (output #01) is to be tested, by pressing the UP arrow key and holding it down, the output will come on and stay on. When the key is released the output will go off.

Press **MENU** (Right Arrow) and you will advance to the next output to be tested. Pressing the **UP** arrow in any Test Output screen will turn the output ON. Some outputs are programmed to run only briefly, others will run as long as the **UP** arrow key is pressed.

Refer to Section VII for a list of the 17 outputs that can be tested.

This concludes the selections in TEST OUTPUT menu.

Press **ENTER** to loop around to the start of the menu again.

10. Copyright

Press the **MENU** key until the following screen appears:

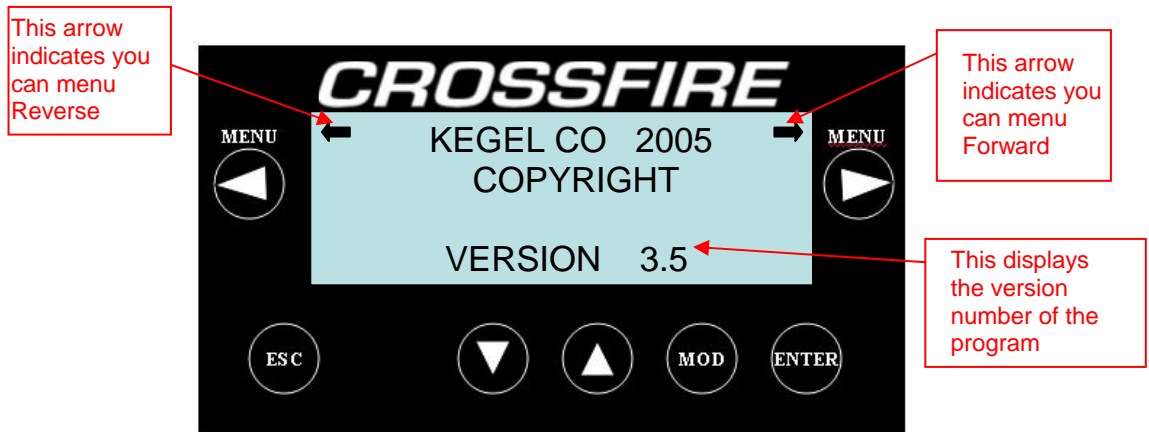

From this menu prompt it is possible to change Data Memories and adjust the clock (after entering the appropriate password). It is recommended that you call Kegel Tech Support if this area needs to be accessed.

On the bottom line of the display, on the far right, is the program version in the PLC. You may be asked for this information during a technical support phone call. The operating program downloaded into this machine when it was produced is identified as **3.5**.

NOTICE: The PLC program is © Copyright protected. Do not attempt to make unauthorized copies of the program or download it into a machine without obtaining permission from Kegel.

This is the last menu available. Press **MENU** to return to the CROSSFIRE RUN SCREEN screen.

11. Set Time/Day Menu

Press the **MENU** key until the following screen appears:



This screen displays the current time. To reset the time and day enter the password and press the **ENTER** key to get to the sub-menus.

Once the password has been entered the following screen appears:



You can change the current time by pressing the **MODIFY** key and moving the menu button (using the left and right arrow keys) over the number you need to change. Once you have changed that value press and hold the **ENTER** key until the screen advances.

CROSSFIRE Operators Manual

After holding down the ENTER key in the SET TIME screen, the following screen appears:

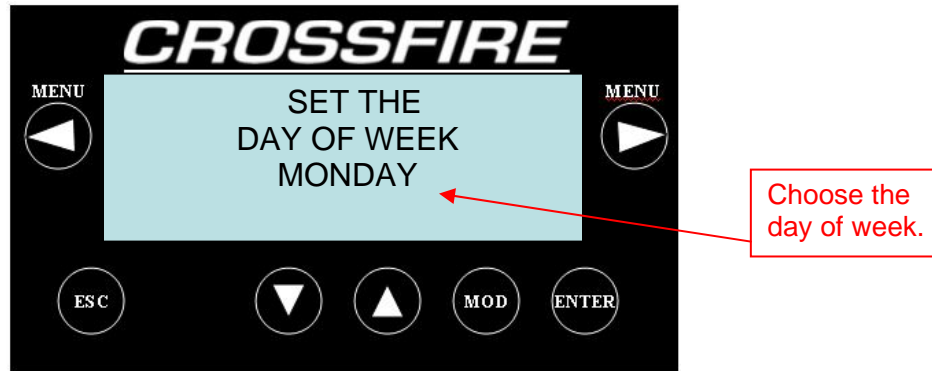

In this screen you can change the day of the week by pressing the MODIFY key and then either use the UP arrow or the DOWN arrow key. Once you have changed to the desired day, press the ENTER key and you will return to the Set Time & Day Main Screen.

SECTION V - Adjustments

A. Cleaning Cloth Replacement & Adjustment

The Crossfire uses a patented Dual Motor Ratcheting (DMR) Cloth system. The duster assembly operates by means of two brake motors. The first unwinds cloth and sets the cushion roller down on the lane surface. The second winds up used cloth onto the used core.

The wind-up motor also lifts the cushion roller off the lane at the end of the run. This dual action simulates that of a ratcheting duster, helping to eliminate dirt lines during a conditioning run. This system also controls cloth usage better, and has no clutch mechanism to adjust.

IMPORTANT! The machine can NOT be operated without Lane Cleaning Cloth installed.

Lane Cleaning Cloth should be loaded into the machine using the following procedure:

1. Remove the cleaner dispensing tip from the holder and then remove the old cloth.
2. Remove the pipe from the old duster core and insert into the new one. Unroll about 3 feet of cloth and then install the new roll into its location.
3. Route the cloth down between the squeegee and the cushion roller. Pull the cloth under the cushion roller and distribute evenly.
4. Once the cloth is routed under the cushion pull the excess cloth far enough through to get at least 3 or 4 wraps around the take-up reel. Make sure the cloth is wrapped evenly from side to side around the pipe. If necessary use the PVC clamps to hold the cloth.
5. Insert the take-up roll into its location and replace the cleaner dispensing tip.
6. Apply power to the machine and bring up the **SYSTEM CONTROL DUST** menu.
7. The start button on the handle can be used to take-up the slack from the fresh roll of cloth. Push and hold the button in, the unwind motor will operate until the button is released. The next time the button is pressed and

CROSSFIRE Operators Manual

held in, the wind-up motor will run until the duster up switch is actuated. The cloth should be rolled up taut and evenly across the assembly.

A sticker similar to the diagram below is affixed to the machine as a reference for proper cloth routing.

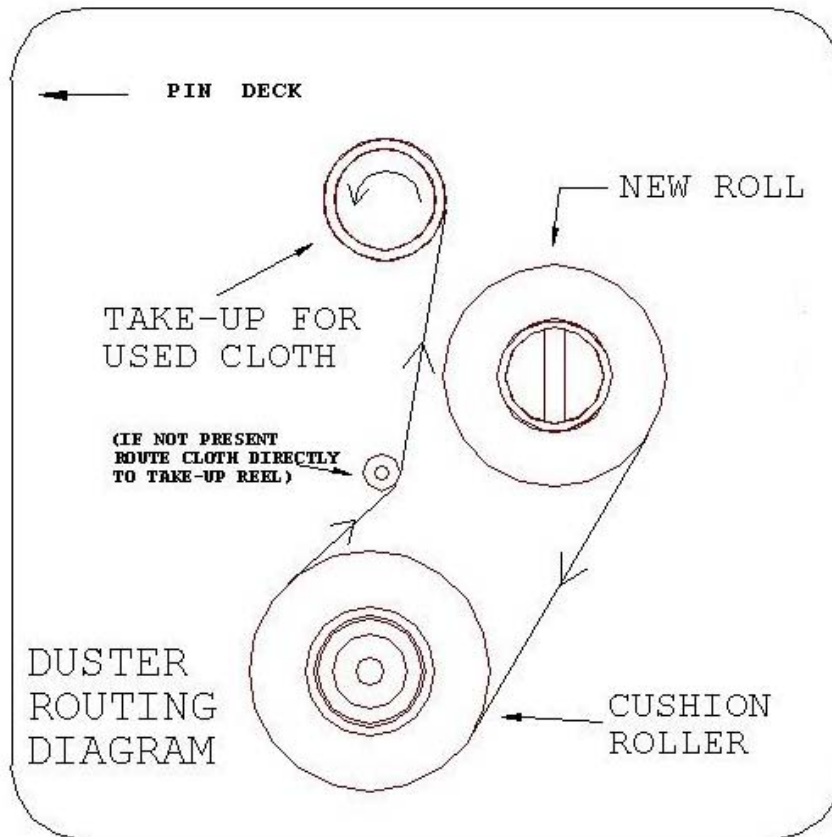

B. Filling of Cleaner Supply Tank

To fill the Cleaner Supply Tank, the machine should be in the down or operating position.

Prepare an appropriate mixture of cleaner and water.

Disconnect power, and place a rag under the tank.

Open the cap and pour the mixture into the Supply Tank using the supplied funnel.

Fill the tank until the fluid is about 1/2" from the top of the tank. Do NOT overfill this tank.

NOTE: The supply tank on the machine is removable for cleaning when necessary.

CAUTION: Do not spill cleaner inside the machine. Spills may "short" the electronic components and cause the machine to malfunction. A wet switch may also produce a dim INPUT LED light on the PLC.

Any spills or drops of cleaner should be wiped up immediately!

C. Emptying of Recovery Tank

NOTE: If you notice foam build up in the tank due to soft water conditions at your facility, it is necessary to purchase a de-foaming agent.

To empty the Recovery Tank, the machine must be in the down or operating position. Disconnect the inlet from the side of the recovery tank and the outlet hose from vacuum plate by removing the PVC elbows.

Remove tank from machine and dispose of used cleaner **properly**. Do NOT dump recovery tank in a septic tank or sanitary sewer system. Follow your local environmental regulations for the best method of disposal.

NOTE: When dumping liquid from Recovery Tank, it is best to let liquid flow out the inlet end, or the end which was connected to the squeegee assembly. If liquid accumulates on the opposite side of tank, dirty cleaner may be

discharged from the vacuum exhaust and onto the lane until the line is cleared.

It is recommended that the inside of the tank and the filter material in the tank be cleaned periodically. Set the tank on a flat surface. Remove the phillips screws from both covers, use a flat-head screwdriver to gently pry covers off. Clean silicone residue from both covers and the tank. Remove filter material from the tank and rinse thoroughly with clean water. Use a clean rag to wipe any dirt or residue from the inside of the tank. Replace filter material in the correct position in tank (filter material is not square, material will only fit one way in tank). Place a bead of silicon on the area where both covers will seat. Replace fasteners in both covers and tighten down. DO NOT over-tighten. Allow silicone to cure before operating machine.

To reconnect the tank, reverse the disconnect procedure.

D. Adjustment of Spray Jets

The machine uses a three spray jet system to spray cleaner onto the lane surface. These specially designed stainless steel jets spray in a "V" pattern and when properly adjusted spray cleaner across the entire width of the lane.

The spray jets are factory-set, but may need to be adjusted so all boards across the lane are covered, and so that overspray into the channels does not occur.

If coverage is too narrow and edge boards are not being sprayed, adjust by raising the spray tips slightly, or rotating the jet mounting angle.

If coverage is too wide and overspray occurs, adjust spray tip down or toward the center.

To adjust, simply loosen the hex bolt on the aluminum body of the spray assembly. Rotate the spray jet up or down as needed. The middle tip is at an angle, positioned at about a 45-degree or a 135-degree angle. Adjust this jet until you get the best spray pattern, then tighten hex bolt.

The mounting angles for the outside jets can be angled toward the center to eliminate any overspray into the channels. The tips of the outside jets should basically be positioned vertically.

E. Guide Roller Adjustments

Adjustment of the guide rollers may be needed if the bowling center has lanes that have been injected, or if the channels are even with the lane surface. In most cases adjustment to the guide rollers on one side will be all that is required. The guide rollers in the front half of the machine are different than those in the rear half, but the adjustments are the same.

To adjust the front guide rollers, remove the bottom bolt that holds the mounting block to the frame. This provides clearance to remove the guide roller, spring, bronze bushings, and the shoulder bolt from the mounting block on the front roller. The rear roller and mounting block should be removed completely from the machine.

One bronze bushing is normally between the roller and the side plate of the machine and one is between the head of the shoulder bolt and the wheel (in the front section of the machine only).

Place the bronze bushing located toward the side plate between the head of the mounting bolt and the guide roller on one side of the machine (both front and rear rollers). This will give approximately 1/4" additional clearance between the guide rollers as the machine travels on the lane surface.

Operate the machine after changing one side. If needed, change the other side of the machine.

F. Squeegee Assembly Adjustment

The Squeegee Assembly is adjusted at the factory to ensure proper cleaning. This adjustment should be checked when the machine is installed. The factory "zero" point is measured on the pivot mounts that secure the squeegee to the sides plates. The gap between the bottom of the side plate and the bottom of the pivot arm should be about 1/8" on both sides of the machine.

To check this adjustment and make changes, the machine should be in the upright or transport position. The squeegee will need to be lowered to the down position. To lower the squeegee, apply power to the machine and menu to the **TEST OUTPUT** screen.

When you reach the TEST OUTPUT section, press the RIGHT MENU key and advance to OUTPUT #07.

Press the UP ARROW key once to actuate. The squeegee motor will activate and rotate 180°, this will lower the squeegee. If the squeegee does not stop in the down position, check the condition of the Squeegee Down Switch.

With the squeegee down, take a straight edge and place it from the squeegee blade across the drive wheels to the lane distance wheels. The gap between the straight edge and the drive wheels should be **1/8"** to **3/16"** on each side.

If the distance is more or less, loosen the bolts (two on each side) that hold the squeegee pivot in place. Move the pivot mount until the squeegee height is correct. This should be done for both the left and the right side. Tighten the bolts with the blocks positioned squarely to the side plate after the adjustment is acceptable.

CROSSFIRE Operators Manual

The tilt or pitch of the squeegee may also need adjusted to ensure that both blades are contacting the lane squarely. If a pitch adjustment is necessary, follow these steps to make the adjustment. Make sure the squeegee motor does not bind up when making an adjustment. If the link is too short the motor cannot rotate 360°.

1. Locate the squeegee motor on the right side plate of the machine. Mounted to the motor shaft (inside the machine) is a cam. Mounted to the cam is a rod end and rod. This rod lifts and lowers the squeegee.
2. Remove the bolt that connects the rod end to the cam.
3. Loosen the jam nut between the rod end and the rod.
4. Rotate the rod end as needed to increase or decrease the pitch. Do NOT make the linkage too short.
5. Tighten the rod end to the rod with the jam nut.
6. Re-install and tighten the bolt to connect the rod end to the cam.
7. Re-check the gap between the straight edge and the drive wheels on both sides of the machine.
8. Check cleaning to ensure adjustment is adequate.

NOTE: Excessive crush on the squeegee will cause it to not strip properly and will cause undo stress on the assembly.

G. Buffer Brush Adjustment

The buffer brush is manufactured of a long-lasting synthetic bristle which, under normal circumstances, can be expected to last approximately 18 months. An Amp Draw should be taken on the buffer motor when adjusting the brush. Too much "crush" can cause excessive load on the motor and wear on the brush.

NOTE: Amp draw is also affected by the amount of crush the transfer roller has into the brush.

To check the buffer brush adjustment the brush must first be lowered onto the lane. This is done at the **TEST OUTPUT** menu. If the brush is not already down in the "zero" position, press the ENTER key until BRUSH LIFT MOTOR (OUTPUT #02) is displayed.

Press the UP arrow key to activate this output. This will lower the Buffer Brush into the operating position. If the brush does not stop in the down position, check the condition of the Brush Down Switch.

With the brush down, stand the machine in an upright position and hold a level or straight edge across the drive wheels and rear lane distance wheels. The buffer brush material should extend approximately **3/32"** to **3/16"** beyond the level for proper adjustment. This crush is determined by the amp draw of the buffer motor and smoothness of the conditioning pattern. The buffer brush is factory adjusted prior to being shipped at approximately 1/8".

If an adjustment is needed, determine how much, and then place the machine on the approach in the operating position. Locate the adjusting screws. Loosen the jams on the two adjusting screws, along with the three lane distance shaft pillow blocks.

Turn the adjusting screws until proper adjustment is reached (each full turn on an adjusting screw is equal to 1/16" adjustment.) Tighten the jam nuts on the adjusting screws.

CROSSFIRE Operators Manual

Make sure that the LDS pillow blocks are firm against the adjusting screws and then tighten the pillow blocks. Always tighten the center block last.

Once the block are secure, check that the LDS shaft turns as freely as possible, and that there is a small amount of end play in the shaft. If the shaft does not spin freely, check and make sure the shaft is square throughout the LDS blocks.

NOTE: When cleaning the Buffing Brush, NEVER use any type of cleaner on the brush material. Use of cleaners will decrease the brush's ability to hold conditioner, and greatly affect the lengthwise taper of the conditioner pattern. All that is needed to clean the Buffer Brush is a clean, soft, dry rag. Wipe the brush clean daily.

H. Transfer Roller Adjustment

The amount of crush the transfer roller has into the brush can be easily adjusted by raising and lowering the transfer assembly. The factory setting is about $5/32$ "; there is a scribe mark on the inside of the side walls on each side of the machine to show the factory adjustment.

To adjust, loosen the mounting blocks on each end of the roller. Also loosen the transfer roller motor to create slack in the chain. Move the roller up or down until the desired amount of crush into the brush is obtained.

Make sure the transfer roller is level and parallel to the brush so the crush is the same on the left and right side. Tighten the two mounting blocks, re-adjust the chain tension, and tighten the transfer roller motor.

I. End Cleaning Distance Travel Adjustment

When the machine is installed the End Cleaning Travel Distance must be checked and adjusted.

This distance is different in each bowling center around the world. These vary because of specification tolerances that are allowed during the construction of the lanes. Always leave a margin of error when setting the end cleaning distance. This can be accomplished by starting the machine a couple of inches past the foul line when making this adjustment.

Making sure that the machine is traveling the correct distance is important to how well the pindecks are cleaned. If the pindecks are not getting cleaned well enough, the pins slide more, creating Out-of-Ranges. This is an unnecessary call for any bowling center.

To adjust the pindeck travel, go to the **SYSTEM CONTROL CLEANING** menu and press the **ENTER** key until the screen reads:

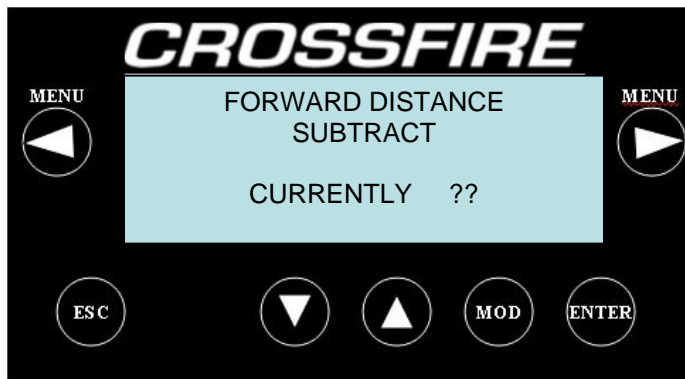

Increase the number with the Up Arrow to go shorter, decrease with the Down Arrow to go longer. After the change is made, run the machine and observe where the machine stops at in the pindeck area. The diagram on the next page gives a reference point of where the machine should stop when the squeegee has completely cleared the tailplank.

Note: An adjustment may be necessary in the **REVERSE DISTANCE SUBTRACT** menu when travel settings are changed. It should be adjusted so the machine travels the correct distance back to the foul line. The return distance should be a little

less than the End Cleaning Distance. Adjust the setting to control the reverse travel distance, when necessary.

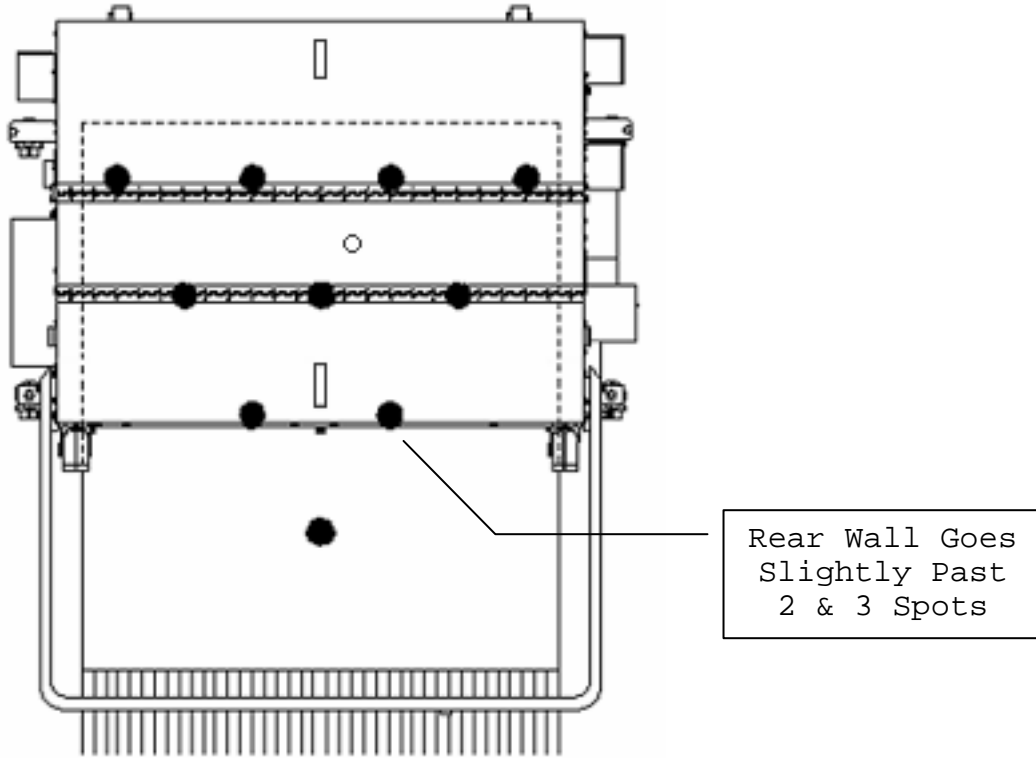

Proper Position of Machine in Pit

J. Drive Motor Speed Adjustments

To set the drive speeds you will need to Menu to the **Set Low Speed** screen. You will be able to check and set the LOW speed of the machine while in this screen.

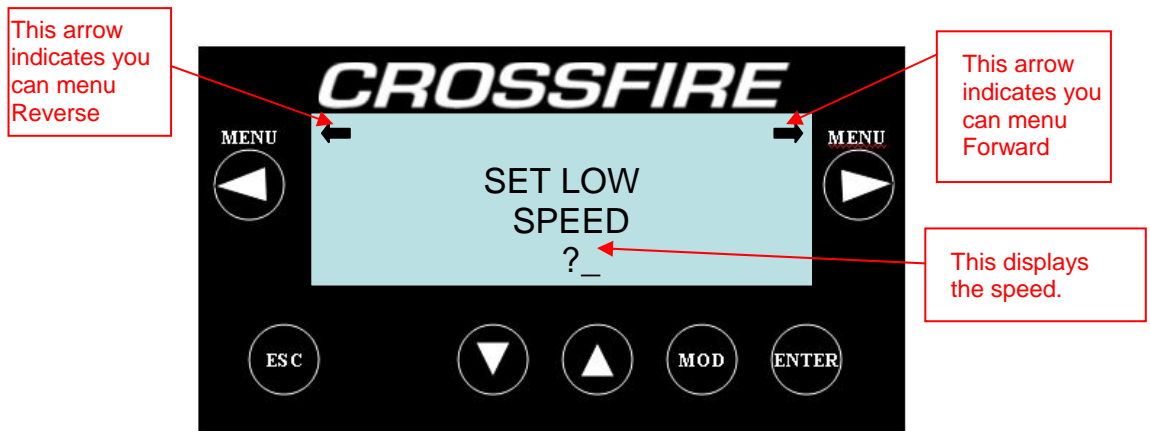

CROSSFIRE Operators Manual

The factory-set speeds from low to high will toggle between the following numbers:

09-10 IPS Low Speed
19-20 IPS Second Speed
26-27 IPS High Speed

If a speed adjustment is needed, locate the adjusting trimpots mounted to the frame to the left of the PLC. The speeds go in order from left to right (low to high) and are adjusted with these three trimpots.

The speeds will increase when their respective trimpot is turned clockwise. When adjusting the speeds, always start with the low speed and work up to high speed. Here's how to do this step-by-step.

1. After you have reached the Set Low Speed screen, push the machine onto the lane. Press the Start Button on the handle one time. The machine will travel 30 feet down the lane, stop, and travel back to the foul line at low speed. You will need to walk next to the machine as it travels. The screen may toggle back and forth between speeds. Use the left-most trimpot to adjust the speed to the desired setting (the screen should flash evenly between 09-10 for the low speed). If it is too difficult to adjust the speed while the machine is moving, you can pause the machine. Press the Start Button one time to pause the machine. After you have adjusted the trimpot, press the Start Button again to have the machine resume its test run.
2. Press MENU to advance to the next speed. Follow the same procedure from STEP #1. Adjust your second speed to 19-20, then advance to the high speed screen by pressing MENU and adjust accordingly if needed.
NOTE: Just before the machine reaches the end of its travel in high speed, it will shift to low speed for the last couple of feet. This is to prevent excessive stress on the machine from a sudden stop at high speed.
3. If one of the speeds can't be reached, an adjustment to the DC Speed Control board might be required. Call Kegel for technical support if needed. If changes are made to the adjusting pots on this board, always go back to Speed 1 and check all the speeds again.

CROSSFIRE Operators Manual

4. If the speeds don't match, it will be necessary to make an adjustment to the Speed Control board. The following steps outline this procedure.
5. Remove power to the machine.
6. Locate the Speed Control, it is attached to and directly below the speed trimpots. There will be a trimpot on the board labeled **IR**, this is a compensation adjustment. This adjustment is used to equal the load and no load speeds.
7. If the machine is traveling faster than it should, then you will need to turn the trimpot counter-clockwise. If the full-load speeds are slower, turn it clockwise. If the speed difference is not much it will be a very small adjustment.
8. Run machine on the lane and check all 3 drive speeds, repeat the step above if needed.

Section VI - Maintenance

Maintenance: The following items should be done to the machine on a regular basis:

A. Power Cord

Care should be taken to see that the power cord is handled properly and stored correctly.

Do **NOT** wrap the cord around the machine for storage. Some type of cord wrap or cord spool for storage will add life to the cord. Make large loops when wrapping the cord.

Should the power cord become damaged or frayed, it should be repaired or replaced **IMMEDIATELY!**

To keep the power cord clean, pull it through a rag as the machine is being operated on every lane. Only replace the cord with one that is identical to the factory specifications.

Important Note About The Power Cord

The machine power cord is certified to comply with UL, CSA, and CE Safety Directives. To achieve all these certifications, two of the wire conductors in the cord are colored **BLACK**.

Each conductor has a number printed on it: 1 or 2. The #1 conductor should be connected to the **HOT** leg (L1) of the voltage source. The #2 conductor should be connected to L2 or the **NEUTRAL** leg of the voltage source (if applicable on 230V). Make sure to follow the proper wiring instructions when replacing the cord ends. Use only cord stock equivalent to the factory specifications.

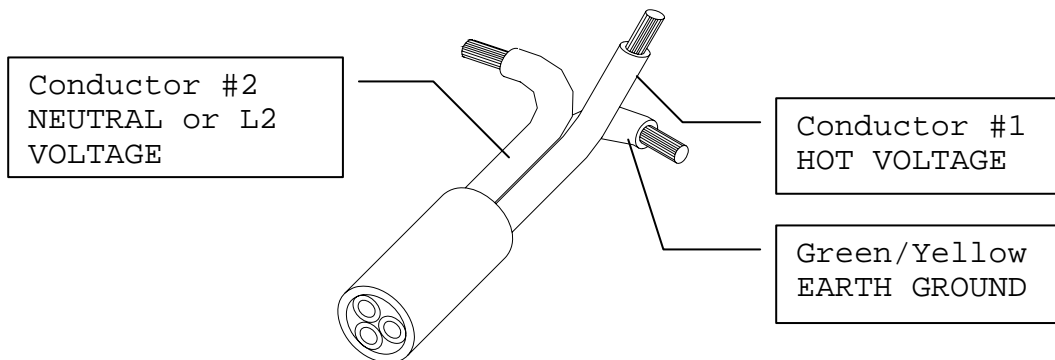

B. Squeegee

Wipe the blades and housing with a clean cloth after each operation. Check the blades for wear and tear. The edges of the blades should be sharp and square. Rounded edges mean it's time to replace the blades.

C. Lane-to-Lane Casters

Clean after each operation.

D. Drive Wheels

Clean daily after each operation.

E. Vacuum Motor

Important! This motor should be wiped off daily and blown out weekly. This is especially important in high dust areas, or bowling centers who do not dust gutters and caps daily. Dirt can build up on the electrical end of the motor which will obstruct the air flow. This will result in increased heat and wear of the brushes and commutator. This will drastically decrease the life of the vacuum motor. You have been warned!

The vacuum motor is mounted by two bolts on the cleaner wall, removing the lid will make it easier to remove.

F. Inside Machine

Wipe up excess dust and dirt daily. Pay close attention to the computer compartment to keep dirt from damaging the PLC and components. Avoid spilling liquids inside the machine.

G. Recovery Tank Removal

Remove and drain (from inlet end) after each operation. Always drain the recovery tank when filling the supply tank.

H. Filters

The cleaner tank has a large internal filter. There are three check-valve filters, one on each spray jet that should be checked.

Periodically clean these filters to keep the machine operating at peak performance.

I. Wicking Pads

The wicking pads will need to be replaced periodically. Cleaning any accumulation of dirt and dust from wicking pads after every conditioning run will extend their life. USE A SOFT RAG ONLY!! Metal or abrasives will tear at the wick material, causing wick deterioration and irregular conditioner flow.

WICKING PAD REMOVAL: To remove a wicking pad for cleaning or replacement, remove both springs from the eyebolts on the wick assembly. Pull the pad out of the trough. To replace the pad into the trough, simply reverse the procedure.

NOTE: When the wick pads are removed always inspect the trough for debris. Clean any accumulation out of the trough and inspect the area where the conditioner re-fills into it.

WICKING PAD CLEANING: To clean the wicking pads, wipe the wick material with a clean, dry cloth until all loose dirt particles are removed.

WICKING PAD REPLACEMENT: When it becomes necessary to replace the wick material on the Crossfire wicking pads, use only genuine Kegel replacement material. These items may be ordered from your Authorized Distributor. Any combination of pad sizes can be used, as long as the sizes of the six or eight pads all added together total 40-inches.

CHANGING OF CONDITIONER: It is not always necessary to replace the wicking pad material when the type of conditioner being used is changed. When changing conditioners, remove all wicking pads from the machine and drain the conditioner tank and trough completely.

CROSSFIRE Operators Manual

Using a clean, dry towel, squeeze the wicking pads to remove as much of the old conditioner as possible. Use several towels if necessary. Before replacing wicking pads into the conditioner tank, saturate each pad with the new lane conditioner to be used. This can be done by using a dispenser such as a clean, empty ketchup bottle, or by laying the pads into a small shallow pan filled with about 1/2" of lane conditioner.

Once saturated, re-install all of the pads into the trough. Fill the tank with the new lane conditioner and allow the trough to become full.

J. Buffing Brush

If build-up of dirt occurs, the brush should be wiped with a clean cloth. Do not use any type of cleaner. Cleaning agents can affect the material, which can change the brush's ability to hold conditioner.

Section VII - Inputs and Outputs

A. Inputs

The PLC assembly of the machine has 24 inputs and 24 outputs (with the expansion module). Inputs accept data from various components in the machine, and then the PLC uses that information to control functions of the machine through its outputs. As an example, distances are input to the PLC from the lane distance sensor, at which point data in the computer program activates certain outputs. An output example would be one of the brake motors.

Here is a list of the **INPUT** numbers that are used on the PLC, along with their designations:

<u>INPUT</u>	<u>DESCRIPTION:</u>
0	BRUSH DOWN SWITCH
1	CAMSHAFT ZERO SWITCH
2	LANE DISTANCE SENSOR (LDS)
3	NOT USED
4	OIL ONLY SWITCH
5	CLEAN ONLY SWITCH
6	START BUTTON
7	DUSTER UP SWITCH
8	SQUEEGEE DOWN SWITCH
9	SQUEEGEE UP SWITCH
10	AUX OIL FLOAT (OPTIONAL)
11	CAM INDEX SWITCH
12	BRUSH UP SWITCH

B. Outputs

The following is a list of all the Test **OUTPUT** numbers and their descriptions:

<u>TEST #</u>	<u>DESCRIPTION:</u>
#01	CAM MOTOR
#02	BRUSH LIFT RELAY
#03	BUFFER MOTOR
#04	DUSTER UNWIND MOTOR
#05	DUSTER WINDUP MOTOR
#06	VACUUM MOTOR
#07	SQUEEGEE MOTOR
#08	CLEANER PUMP
#09	FORWARD DRIVE RELAY
#10	REVERSE DRIVE RELAY
#11	TRANSFER ROLLER MOTOR
#12	AUXILIARY OIL VALVE (OPTIONAL)
#13	SPEED 1
#14	SPEED 2
#15	SPEED 3
#16	SPARE OUTPUT Q1.6
#17	SPARE OUTPUT Q1.7

C. Description of Inputs

Brush Down Switch: This switch is located on the mounting plate between the plate and the Up Switch. When the lobe of the cam actuates this switch, the PLC receives a signal that the brush is in the DOWN position. The down switch must be actuated for the buffer drive motor to function during any conditioning operation. This switch is wired Normally Open. The brush parks in the Down Position and this switch indicates the brush is in the zero position.

Camshaft Zero Switch: This switch indicates that the camshaft is in its "home" position or starting point.

LDS Pulse: This proximity sensor is mounted on a block on the rear wall of the machine. A metal target passes in front of this sensor as the shaft turns. It counts in one-inch increments as the machine travels down the lane. If this sensor does not send pulses to the PLC, the machine will display an Error Code.

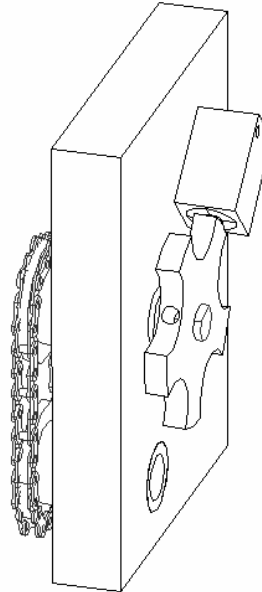

Oil Only Switch: This input tells the PLC to apply conditioner without cleaning the lane. Flipping the toggle switch on the control panel to "Condition Only" will turn this operation ON. In this mode the duster can be turned off if needed.

Clean Only Switch: This input tells the PLC to clean the lane without applying conditioner. When cleaning, the shift points for the speeds are the same as if the machine was running a conditioning program. Flipping the toggle switch on the control panel to "Clean Only" will turn this operation ON.

CROSSFIRE Operators Manual

Start Button: Located on the handle, this normally open push button has a couple of different functions during operation.

- With the machine in the RUN mode, when the button pressed for the **FIRST** time, it will send a signal to the PLC. This signal will tell the PLC to run specific outputs as needed in the program (i.e. lower the squeegee and duster cloth).

The **SECOND** time the button is pressed, the PLC will begin running the program on the lane.

NOTE: The **UP ARROW** is also a backup switch that can perform all the functions of the Start Button.

- During operation, the button acts as a **Pause and Resume** Button for the machine.
- In the **Manual Reverse Menu**, when the start button is pressed and held, the machine will travel in reverse at 20 IPS.
- In the **System Control Duster** screen, the FIRST time the button is pressed, the brake motor will unwind cloth while the button is held.

The **SECOND** time it is pressed, the motor will wind-up cloth. The wind-up motor will stop running when the Duster Up Switch makes contact.

CROSSFIRE Operators Manual

Duster Up Switch: These two microswitches are located on the top side of the Cushion Roller Pivot Arms, on each side of the machine. When the cloth is wound up, a screw in the pivot arm activates the switch and a signal is sent to the PLC by one (or both) of these switches. These switches are wired Normally Open.

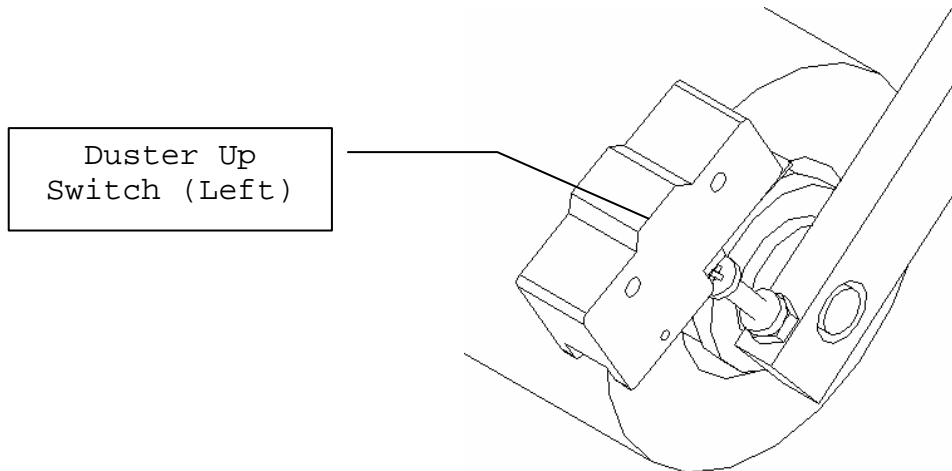

Squeegee Down Switch: This switch is located on the right inside wall of the cleaning compartment, just above the cam. The microswitch tells the PLC when the squeegee is in the DOWN position. A signal is sent to the PLC when the switch is actuated by the cam lobe. While operating the squeegee must be in the down position. If the PLC does not get the signal from this switch, an error message will appear on the screen. This switch is wired Normally Open.

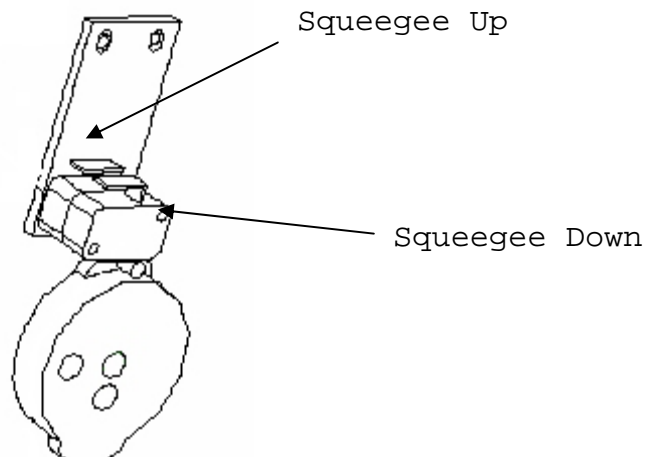

CROSSFIRE Operators Manual

Squeegee Up Switch: This switch is located on the right inside wall of the cleaning compartment, just below the cam. The switch works the same way as the Buffer Up Switch. When the cam lobe actuates the switch, the PLC receives the signal telling the machine the squeegee is UP. This switch is wired Normally Open. The squeegee parks in the Up Position and this switch indicates the squeegee is in the zero position.

Auxiliary Oil Float (Optional): On an upgraded machine is a float to monitor the conditioner level. During operation, this float sends a signal to the PLC when the level is low. This causes a valve to open and re-fill the wick tank. This allows the machine to maintain a consistent amount of conditioner for the wicking pads.

This float is important for consistent operation of the machine in larger centers. Without it, there may be reduced conditioner output across many lanes.

During operation, the re-fill valve will open automatically.

NOTE: If this valve fails, excess conditioner may be allowed to flow into the tank trough.

Cam Index Switch: This switch indicates how many indexes the camshaft has made, it will be 3 or 4, depending on your machine setup.

Brush Up Switch: This switch is located on an adjusting plate, mounted on top of the Down Position Switch (it's the outside switch). When the lobe of the cam on the motor shaft actuates this switch, the PLC receives a signal that the brush is in the UP position. This switch is wired Normally Open.

<p>NOTE: All microswitches on the machine are wired Normally Open. When replacing switches, make sure the wiring is connected to the COM and NO contacts.</p>
--

SECTION VIII - Program Descriptions

A. Sample Pattern Settings

The programs in this section have been created by Lane Maintenance Central. Contact Kegel at (863) 734-0200 or (800) 280-2695 for information about these or other patterns.

Pattern Trouble-shooting Tips

Here are some suggestions to common questions about lane conditioning. These tips should help you make the proper adjustments to the patterns supplied in this manual.

Q: What should I do if I have too much **carry down**?

A: Shorten the applied oil distance. Too much oil in the middle, at the end of the pattern, causes carry down. Change only the buff-out distance, do not shorten the pattern, as this only creates more transition and possibly more moves. Make sure the machine is cleaning properly before making any pattern adjustments.

Q: What should I do if the **backends** are too strong?

A: Lengthen the pattern to tone down the reaction. Tamer backends provide predictable ball reaction and makes spare shooting easier. Be aware of potential carry down problems when the pattern length is increased.

CROSSFIRE Operators Manual

Q: What should I do if I do not have enough **hold**?

A: The distance of the applied oil on the return pass creates hold. This area is known as the mid-lane (from about 18-32 feet). The mid-lane provides direction to the breakpoint and dictates the score-ability of a pattern. Starting the reverse oil farther down the lane will help increase hold.

Q: What should I do if the **heads hook**?

A: The amount of oil in the lay down area, or a lane surface in poor condition, can cause the heads to hook. In both instances, the lane machine should run slower in the heads. This is better controlled on the return oil due to the direction of travel and the rotation of the buffer brush. Apply conditioner during the return travel that finishes close to the foul line.

Q: What should I do if I have no **swing**?

A: The amount of oil on the outside boards, or adverse lane topography, can affect swing. Reducing the length (or volume) of the applied oil will increase the amount of swing. If this is a topography issue, the pattern should be adjusted by reducing the amount of oil on the outside boards to allow bowlers to play a more direct line to the pocket. This should create more area in play at the breakpoint.

Q: What should I do if the **track** dries up too quickly?

A: Many bowling centers do not apply enough oil to the track on both forward and return passes. The volume, in units, at the end of the pattern should be slightly more than the outside boards. Applying oil to the track on the return pass provides longevity and stability. This application of oil can be started further down the lane on the return without drastically affecting the forward oil readings and ball reaction.

A. Sample Pattern Settings

These programs have been created specifically for the Crossfire lane machine. These graphs are only a representation of the patterns that will be applied by the machine. Many variables can affect the graph, so it may not match your machine exactly.

Program 1 is designed for high friction surfaces that are in good shape, for some synthetics, and freshly resurfaced lanes.

Program 2 is similar to Program 1 with less applied oil distance for lower friction surfaces or stronger backends.

Program 3 has shorter applied oil going forward with more length on the return. Designed to create more hold while limiting the carry down.

Program 4 is a starting point pattern for competitive events, wider and flatter to create more angles. Requires a higher skill level than a typical "house pattern".

B. Prodigy Sample Pattern Settings

PRODIGY



These programs have been created using **Prodigy™** Lane Conditioner. These graphs are only a representation of the patterns that will be applied by the machine.

Pattern 1

Pattern 2

Pattern 3

Pattern 4

CROSSFIRE Operators Manual

SECTION IX - Appendix

A. Recommended Maintenance Inspections

DAILY:

1. Clean entire conditioning compartment with a dry towel.
This will help keep the pattern consistent from day to day.
2. Wipe squeegee blades after each use with a damp cloth. When the squeegee dries it becomes tackier, making it harder to clean. **FAILURE TO CLEAN SQUEEGEE BLADES CAN AFFECT THE CLEANING QUALITY AND EFFICIENCY!!**
3. Wipe cord down when wrapping after use. Make large loops.
4. Clean the Lane to Lane Casters, Transport Casters, and the Drive Wheels.
5. Wipe off Vacuum Motor. Lint can clog the air intake.
6. Drain Recovery Tank and **WIPE UP ALL SPILLS IMMEDIATELY!!**
Most cleaners can corrode the paint.

WEEKLY:

1. Clean entire machine with dry towel.
2. Blow out the vacuum motor with air. This is especially critical in high dust areas. Dirt will restrict air flow and cause premature wear of the motor.
3. Keep duster and squeegee position switches clean. Avoid spilling fluids on these or any switches. This may cause the machine to malfunction.
4. Wipe the LDS wheels, drive wheels, and all casters.

CLEANING COMPARTMENT:

When changing the duster cloth, always use this opportunity to clean the front area of the machine.

CROSSFIRE Operators Manual

KEEP YOUR MACHINE LOOKING NEW:

Buffing the machine with a light coat of wax will seal the paint and protect the finish of the machine. This will also help remove deep down dirt and mild stains.

If you really care about your valuable investment, and about the condition of your lanes, you will never regret keeping the machine clean.

MAINTENANCE INSPECTIONS:

Periodic maintenance will keep the machine operating at peak performance. The following 4 pages are checklists that should be used at the appropriate mileage intervals.

While operating, the machine will show the total number of lanes of operation next to the travel speed. You can use this number to schedule your maintenance. However, this reflects the number of times the machine has operated, regardless of whether it was a full-lane cleaning or only a partial run, such as an oil only operation.

To be absolutely sure of the actual travel distance, you would have to perform some mathematical calculations. You can use the simple conversion factors shown below to get a good idea of the mileage the machine has traveled.

Measurements: ~1460 Inches of Travel per Full Lane
12 Inches = 1 Foot
5280 Feet = 1 Mile

Math: $1460/12 = 121.67$ Feet for full lane travel
 $5280/121.67 = \mathbf{43.4 \text{ Lanes per Mile}}$

If the machine is not programmed to travel the entire length of the lane, you will have to add up the distances manually to calculate your maintenance interval.

CROSSFIRE Operators Manual

20 MILE MAINTENANCE INSPECTION

Complete every 20 miles (~868 lanes) of operation

(Use special 100 and 200 mile checklist at appropriate times.)

NOTICE TO OPERATORS: When the 20 mile maintenance is due, please examine the entire machine thoroughly, paying close attention to items listed below on the 20 mile checklist. When your inspection and repairs are complete, review what you have done with your Supervisor.

	20 mile	40 mile	60 mile	80 mile	100 mile	120 mile	140 mile	160 mile
Clean entire machine thoroughly								
Inspect lane-to-lane casters								
Inspect LDS and Drive wheels								
Inspect sensors and switches Clean if needed								
Inspect drive motor brushes & clean cap with compressed air								
Clean buffer brush with air and check adjustment								
Flush recovery tank (use hot water)								
Clean filters and spray tips								
Remove wicks: inspect and clean thoroughly with clean, dry cloth								
Check squeegee for wear and adjustment								
Check all chain tensions								
Check buffer belt tension								
Operator's Initials								
Date								
Actual Mileage								
Supervisor's Initials								

CROSSFIRE Operators Manual

100 MILE MAINTENANCE

Complete every 100 miles (~4,340 lanes) of operation

NOTICE TO OPERATORS: When the 100 mile maintenance inspection is due, please examine the entire machine thoroughly, paying close attention to the items listed below. When your inspection and repairs are complete, review what has been done with your Supervisor.

100 mile	200 mile	COMPLETE THE FOLLOWING INSPECTIONS:
		Complete all 20 mile maintenance inspections
		Inspect all motor pulleys and remove dirt build-up
		Inspect all cleaner supply lines and tee fittings
		Inspect vacuum hoses for breaks
		Inspect all oil lines and fittings.

PERFORM THE FOLLOWING MAINTENANCE:

		Lubricate all drive chains with 2-3 drops of 50W oil
		Lubricate the felt washers with 10W oil until saturated
		Lubricate LDS shaft bushings with 2 drops of 10W oil
		Lubricate buffer belt idler bushing with 3 drops of 10W oil
		Lubricate pivot arm bushings on the duster assembly with 2 drops of 10W oil
		TIGHTEN ALL SET SCREWS (brush, cams, pulleys, sprockets, hubs, and wheels)
		Operator's Initials
		Date
		Supervisor's Initials
		Actual mileage

CROSSFIRE Operators Manual

200 MILE MAINTENANCE INSPECTION

Complete every 200 miles (~8,680 lanes) of operation

NOTICE TO OPERATORS: When the 200 mile maintenance inspection is due, please examine the entire machine thoroughly, paying close attention to the items listed below. When your inspection and repairs are complete, review what has been done with your Supervisor.

200 mile	400 mile	COMPLETE THE FOLLOWING INSPECTIONS:
		Complete all 20 and 100 mile maintenance inspections

COMPUTER AREA:

		Tighten PLC and PLC Mounting plate
		Tighten all terminal strips and wire blocks

CONDITIONER AREA:

		Check transfer roller mounting arms for tightness
		Inspect all wires for tightness and breaks

MISCELLANEOUS:

		Inspect all wires in cleaning end for tightness and breaks
		Test all inputs and outputs (through I/O Test on keypad)
		Check LDS for excessive play (1/16" maximum)
		Check for excessive play in squeegee assembly

CROSSFIRE Operators Manual

200 MILE MAINTENANCE INSPECTION (CONTINUED)

200 mile	400 mile	INSPECT THE FOLLOWING ASSEMBLIES FOR TIGHTNESS:
		Lane guide rollers (4)
		Lane-to-lane casters (4)
		Main drive (5) and LDS (3) shaft pillow blocks
		All frame assembly bolts
		Operator's Initials
		Date
		Supervisor's Initials
		Actual mileage

We recommend replacing the following parts at:

560 miles (23,500 lanes):

560 mile	1120 mile	Part Description		Part #
		Buffer Brush		154-8641
		Cushion Roller		153-8838
		Squeegee Blades		153-8204
		Buffer Belt		154-9615
		Vacuum Motor Brushes		154-0204B (115V) 154-0204C (230V)
		Drive Motor Brushes		154-1809B

We also recommend having the following item on hand after:

1760 miles (71,000 lanes):

1760 Miles	Part Description		Part #
	Speed Control Board		158-1212 (115V/230V)

Recommendations are based on a 32 lane house conditioning twice a day (annually).

B. Instructions To Clean Water Spray Pump

If water pump output is low, the valves inside the pump may be clogged. First clean or replace the internal Supply Tank Filter and the Spray Jet Check Filters. Also check the length of the pressure regulator tubing (length is 6" of 3/16" tubing).

If pressure continues to be a problem, follow these instructions to disassemble the pump and clean the valves. To prevent cleaner from leaking inside the motor, do not remove the Diaphragm Assembly. (See the exploded view on next page.)

DISASSEMBLY:

1. Disconnect power and remove hoses from the pump. Use a rag to catch any cleaner before it spills on the machine.
2. Get the pump out of machine by removing the 4 fasteners holding the pump to the rear wall.
3. With the pump on a workbench remove the Pump Head assembly. The Pump Head is attached by (4) long phillips-head fasteners. (Note: There is no need to remove the (2) recessed screws.)
4. Remove the Pump Valve Assembly. This is the black piece with grills that sits inside the pump head. Make sure the O-ring is in the assembly.
5. Rinse the Pump Valve Assembly with warm soapy water, concentrating on the areas where the cleaner passes through the grills. Do not pry on the black rubber pieces, as damage to these will ruin the valves.

ASSEMBLY:

1. Place the Valve Assembly (with the O-ring) on the Diaphragm.
2. Place the Pump Head over the Valve & Diaphragm Assembly. Make sure the "direction of flow" arrow points from left to right as the pump sits flat on the base.
3. Insert (4) long #10-32 screws until each threads into the Pump Motor, then tighten each screw securely.
4. Replace pump on rear wall with motor toward top of the machine. Replace hoses and test for leaks.

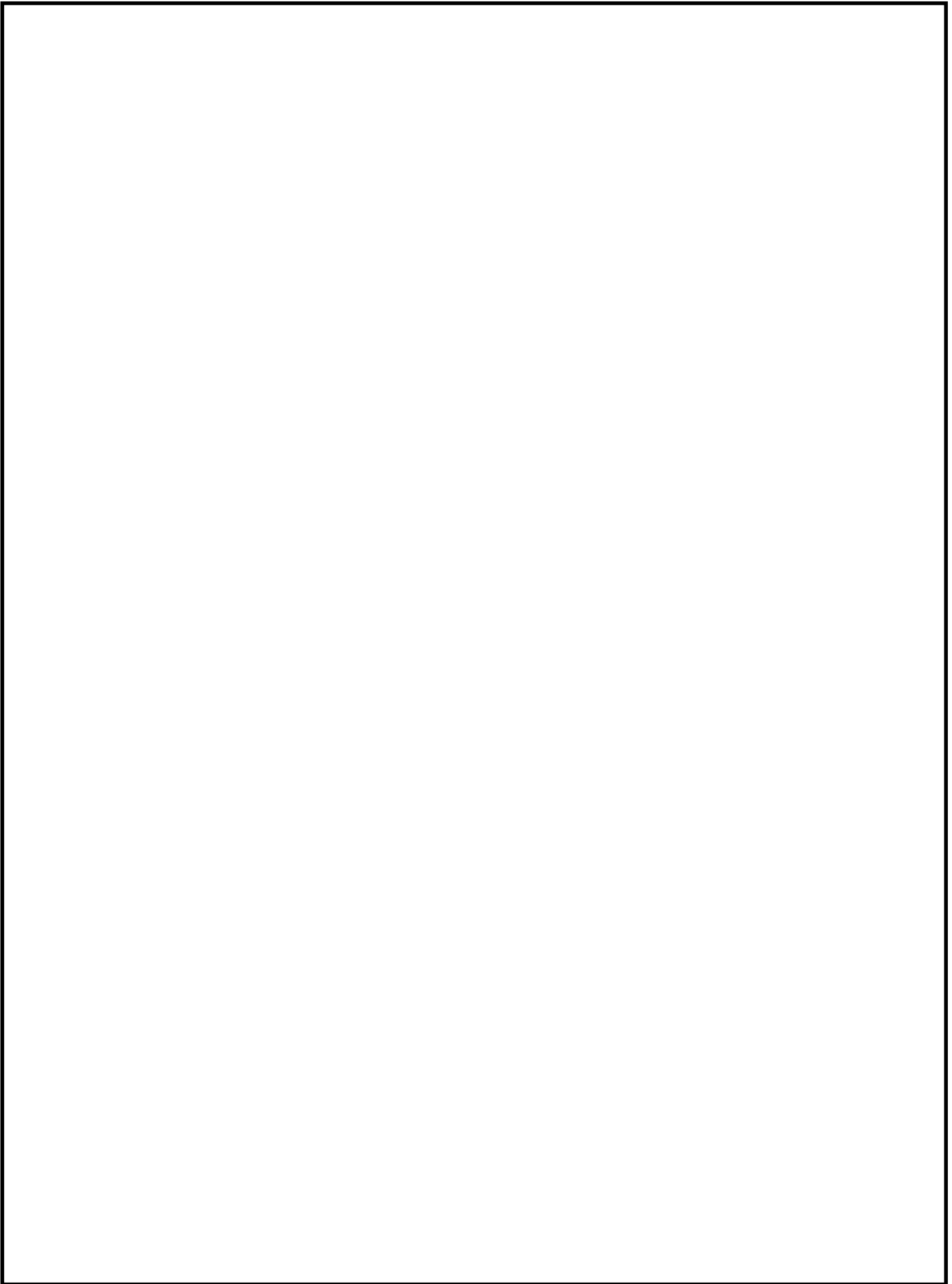

C. Troubleshooting Inputs

To test the Inputs the operator will have to manually activate the device that sends the signal to the PLC. When the Input is activated, the LED light for that Input will light up indicating a good circuit. Refer to **Section VII** for a complete list of all Inputs.

The mechanical switches are all wired to the Normally Open side of the switch, so the switch in its normal position is OFF. Simply depressing the lever of the switch will activate the Input and the LED will light.

WARNING: Do NOT use your fingers to activate the microswitches. When switches are actuated under power, they may cause the output to come on. This can happen when the machine is trying to "zero" itself. Make sure it is safe before checking these circuits.

The proximity sensors are also wired Normally Open. Passing a metal object in front of the face of the sensor will activate the Input; the LED on the sensor and the PLC will go on and off (at the same time) as the metal object passes by the sensor.

Note: Mechanical switches and sensors can be damaged by dirty, oily conditions. Getting cleaner in a mechanical switch can "short" the switch and give a false input. The Input's LED may be very dim, but it will still be received as a good signal.

IMPORTANT: The target passing in front of the proximity switches must be a gap of about 0.020". Gaps greater than 0.035" may cause errors in operation of these sensors.

D. Machine Error Messages

The machine is equipped with Error Messages that are displayed in the event the machine malfunctions. These messages indicate the type of operational error that has occurred with the machine.

DESCRIPTION

FORWARD TRAVEL ERROR

REVERSE TRAVEL ERROR

BRUSH DOWN ERROR

BRUSH UP ERROR

DUSTER UNWIND ERROR

DUSTER WIND-UP ERROR

SQUEEGEE UP ERROR

SQUEEGEE DOWN ERROR

CAM INDEX ERROR

OIL TANK FLOAT ERROR

PRIME PUMP ERROR

TEST SCREEN ERROR

In most cases, correcting the problem and resuming the machine after an Error Message is possible. In some instances, the machine will need to be returned to the fowl line and then re-started.

Follow the Error Message information shown here to get several suggestions as to the reason the error occurred. Along with these suggestions there are troubleshooting suggestions.

CROSSFIRE Operators Manual

The following is a list of the errors that may occur.

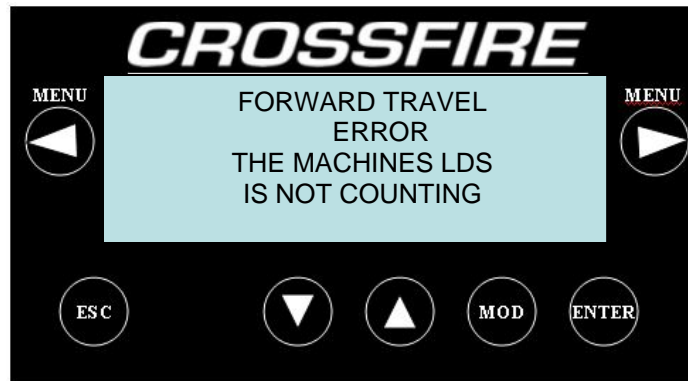

1. Machine is not seated on the lane, there are high gutters, or the drive wheels are slipping.
2. LDS signal failure or the LDS Shaft is binding.
3. Drive Motor or Speed Control failure.
4. Wire is loose or broken.
5. Go to the Test Output Menu and Check Output #09 Forward Drive Relay.
6. Turn the LDS shaft and see if Input #02 is flashing on the PLC as the wheel rotates.

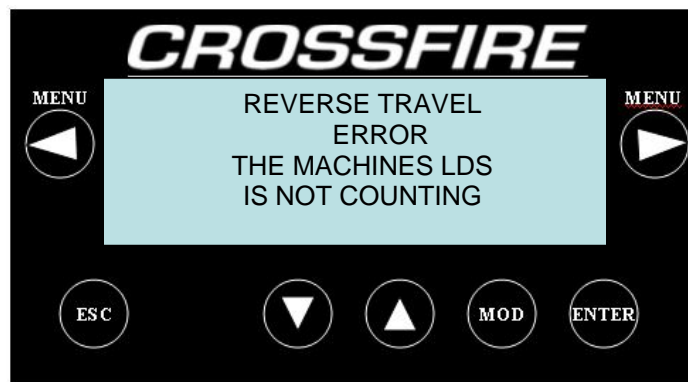

1. The LDS Shaft is binding or the machine is not seated on the lane.
2. Drive Motor or Speed Control failure.
3. Wire is loose or broken.

CROSSFIRE Operators Manual

4. Go to the Test Output Menu and Check Output #10 Reverse Drive Relay.
5. Turn the LDS shaft and see if Input #02 is flashing on the PLC as the wheel rotates.

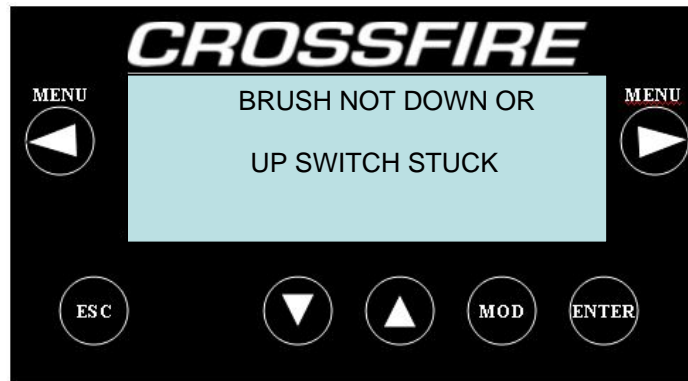

Menu Out of the Program and Return machine to approach.

1. If Brush Lift Motor runs continuously, Input #00 is not getting the signal from the Brush Motor Down Switch.
2. If the Brush Lift Motor does not run, menu to the Test Output screen and check Output #02.



Menu Out of the Program and Return machine to approach.

This Error will occur at the end of the programmed oil distance.

1. If Brush Lift Motor runs continuously, Input #12 is not getting the signal from the Brush Motor Up Switch.
2. If the Program is RESET, the brush should park in the DOWN position. If it does, this indicates the DOWN Switch is good.
3. If the Brush Lift Motor does not run, menu to the Test Output screen and check Output #02.

Note: The Brush Lift Motor and the Squeegee Motor will both time-out in 9 seconds if the position switch it is looking for is not actuated. Before the motor "times-out", the machine should have stopped and displayed an error.



Menu Out of the Program and Return machine to approach.

1. Duster cloth is empty; replace cloth.
2. One (or both) of the Duster Up Switches are stuck. Check if Input #07 has an LED light showing on the PLC with the cloth unwound.
3. Duster did not unwind.
4. If the Duster Motor does not run, menu to the Test Output and check Output #04.



Menu Out of the Program and Return machine to approach.

1. Duster motor did not operate, or the set screw is loose and the hub is slipping on the motor shaft.
2. Make sure the duster rolls are seated in the drive hubs and routed properly.

CROSSFIRE Operators Manual

3. Check adjustment of Wind-Up Switches and see if Input #07 has an LED light showing on the PLC when each of the switches is actuated.
4. If the Duster Motor does not run, menu to the Test Output menu and check Output #05.

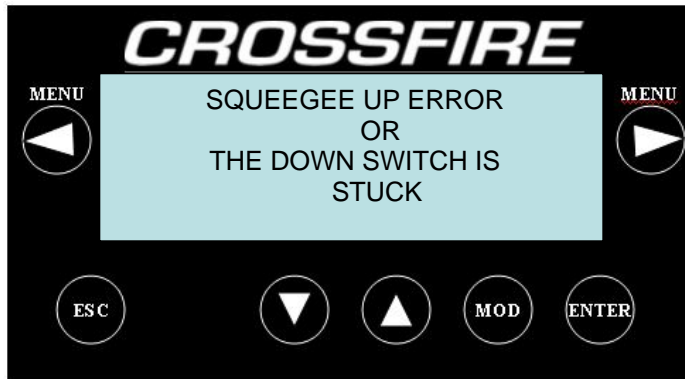

Menu Out of the Program and Return machine to approach.

1. If Squeegee Motor runs continuously, Input #09 is not getting the signal from the Squeegee Up Switch.
2. If Squeegee Motor does not run, menu to the Test Output screen and check Output #07.

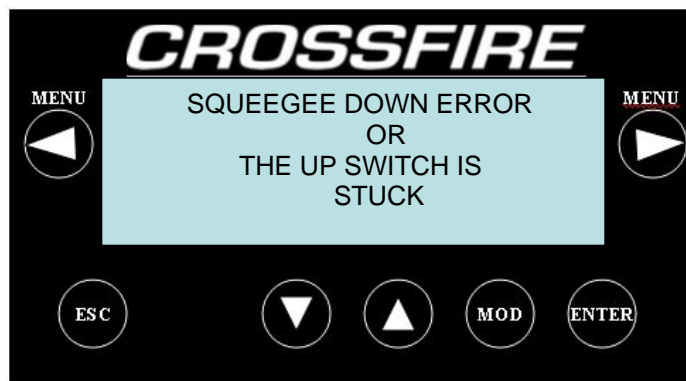

Menu Out of the Program and Return machine to approach.

1. Machine was put on the lane before the Squeegee was lowered.
2. If Squeegee Motor runs continuously, Input #08 is not getting the signal from the Squeegee Down Switch.
3. If Squeegee Motor does not run, menu to the Test Output screen and check Output #07.

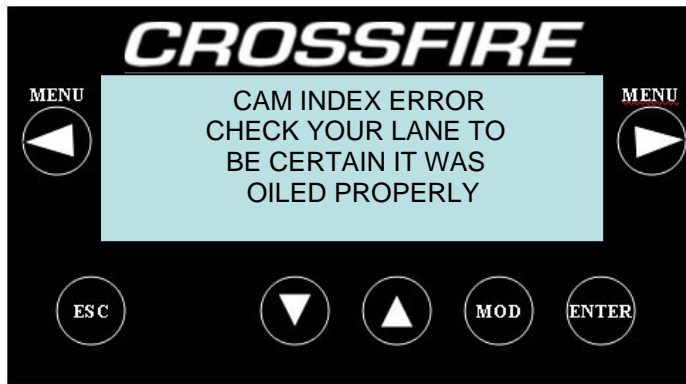

1. Cam motor bad.
2. If Cam Motor does not run, menu to the Test Output screen and check Output #01.
3. Index Motor fuse is blown.

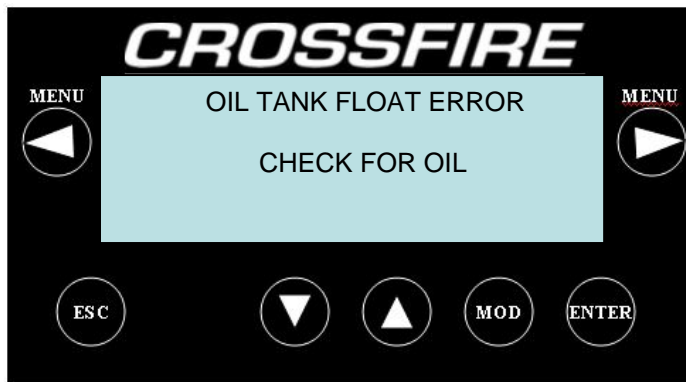

1. Flow of conditioner to the Wick Trough has stopped. If the machine has not received a signal from the float switch in 10 lanes (on a normal clean/condition program), the machine will error and prevent it from operating.
2. The float switch is stuck, indicating a full trough. Inspect the oil level to see if it is below, or even with, the bottom of the wicking pads. Also inspect the area where the float operates to check for free movement.
3. Check the viscosity of the conditioner to determine if it has changed. Oil gets thicker in cold climates.

This concludes the ERROR MESSAGES that are available.

E. Technical Support Instructions

Please follow these steps if there is a problem with the machine.

1. Obtain as much information about the problem as possible. Can you duplicate the problem? If so, **write down** the steps that cause it to occur. Keep in mind that the technical support person will have to fix your problem with the information you provide. The more details you can provide the quicker they can find a solution.
2. Check for error messages while operating the machine. Investigate the suggestions shown in the Manual.
3. Go to the **TEST OUTPUT** menu and check all the Outputs. Test all the Inputs manually. If any of these do not work, inspect the wiring to the component. Each Input and Output also has an LED on the Control Module. These lights can also be used to monitor the machine's functions during operation.
4. Check the Operators Manual to see if it addresses your problem. This may give you enough information to solve the problem yourself, or at least it gives you the background to communicate the problem more readily to a technical support person. **If all else fails...read the manual!**
5. If you still need to call for help, get the following information ready:

_____ **Machine Serial Number** (on bottom of machine)

_____ **Machine Production Date** (on bottom of machine)

_____ **Installation Date**

_____ **Program Number** Where Problem Occurs (if not all)

_____ **Line Voltage** Coming Into The Machine (AC)

CROSSFIRE Operators Manual

6. Get the machine powered-up near a phone **before** you call for help. You should also have a meter handy to check AC and DC voltages and continuity. (This is an especially helpful tool during trouble-shooting.)
7. **Call Kegel at (863) 734-0200.** The Kegel factory is located in Lake Wales, Florida USA. Office hours are typically from 8:00 a.m. to 5:00 p.m. EST Monday through Friday. Calls outside these hours will be handled by an automated message system. Once a message is taken, a tech will be notified and you will be connected or called back as soon as possible.

Following these steps before you call will allow a technical support person to isolate and solve the problem much faster. Each time you call take notes on how the problem was solved to refer back to if the problem occurs again.



SECTION X - Mechanical Drawings

Table of Contents

Edition 04:05

Electrical Wiring Diagrams - 115V/60 Hz : 230V/50 Hz

Terminal Block Diagram

Overhead View	Figure 1
Bottom View	Figure 2
Right Side	Figure 3
Left Side	Figure 4
Conditioning Assembly (6-pad)	Figure 5
Conditioning Assembly (8-pad)	Figure 5A
Control Plate Assembly	Figure 6
Vacuum/Recovery System	Figure 7
Squeegee Motor Assembly	Figure 8
Lane Distance Sensor Assembly	Figure 9
Duster Assembly	Figure 10
Cleaner Supply System	Figure 11
Buffer Brush Lifting Motor Assembly	Figure 12
Attaching Parts Breakdown (Fasteners)	Page 1
Complete Parts List	Page 1



IMPORTANT NOTES